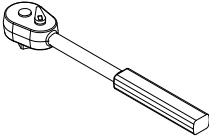
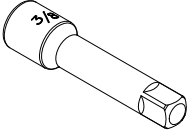
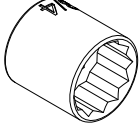
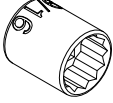
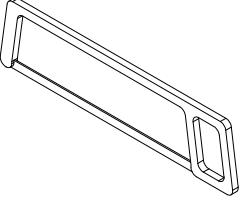
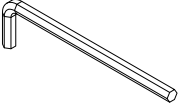
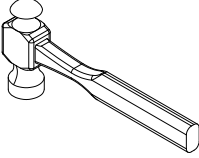
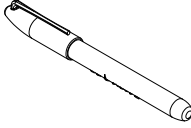
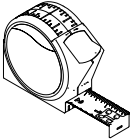

TABLE OF CONTENTS

SECTION	SECTION TITLE	PAGE NO.
1	Assembling Mounting Structure	1
2	Installing Bicycle Mounts	4
3	Adding Sections	12
4	Customizing Rack Configuration	16

REQUIRED TOOLS





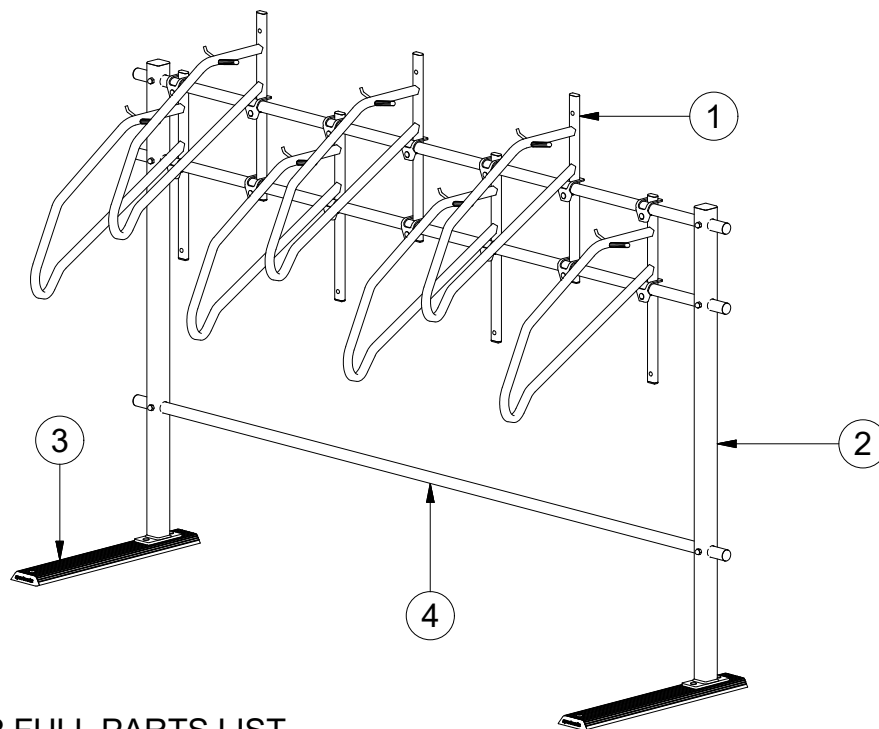

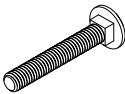

				OPTIONAL
				<p>ONLY NEEDED IF CROSS-MEMBERS ARE TO BE SHORTENED</p> 
RATCHET	RATCHET EXT.	3/4" SOCKET	9/16" SOCKET	
				HACKSAW
5/16" ALLEN	HAMMER	FELT PEN	TAPE MEASURE	

ASSEMBLY PARTS DIAGRAM

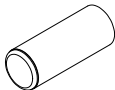
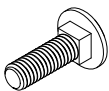

SEE NEXT PAGE FOR FULL PARTS LIST

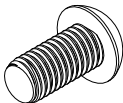
VERTICAL+ PARTS LIST

ITEM	DESCRIPTION	QTY PER
1	BIKE SUPPORT 300306(-XXXX)	1
	CLAMP	2
	CARRIAGE BOLT, 2.5" L.	2
	LOCKING FLANGED HEX NUT	2
	SECURITY RING	1
	LARGE FINISHING PLUG	3
	SMALL FINISHING PLUG	1
2	TOWER 300300(-XXXX)	1
	ENDCAP	3
	CARRIAGE BOLT, 1.25" L.	2
	FLANGED HEX NUT	2
3	MOUNTING RAIL 300301(-XXXX) and 300302(-XXXX)	1
	ENDCAP	2
	BUTTON HEAD CAP SCREW	2
	HEX NUT	2
4	CROSS-MEMBERS 300303(-XXXX), 300304(-XXXX), 300305(-XXXX), 300307(-XXXX), 300308(-XXXX), 300309(-XXXX), 300318(-XXXX) and 300319(-XXXX)	3

SECTION 1 - ASSEMBLING MOUNTING STRUCTURE

STEP 1

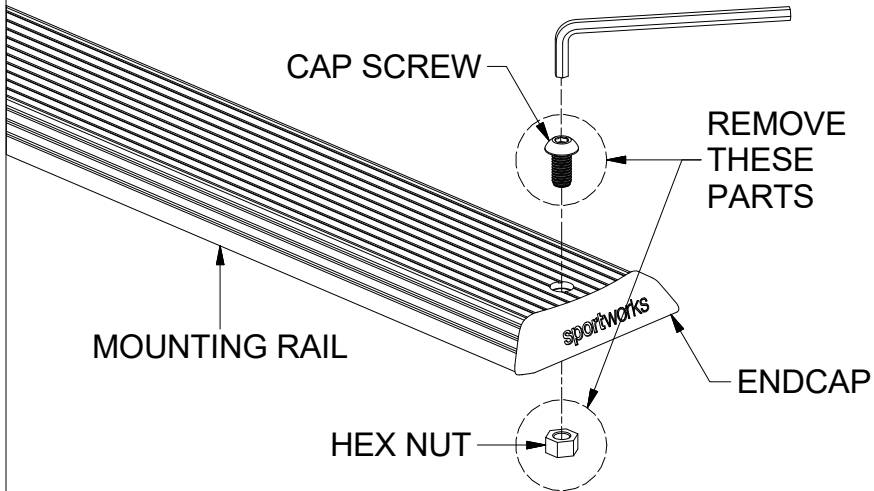

For free-standing double sided racks, skip this step.

For double and single-sided racks being bolted to the floor, use a 5/16" allen wrench to remove all the button head cap screws and hex nuts from the mounting rails.

Ensure all endcaps are left attached to the mounting rails.

STEP 2

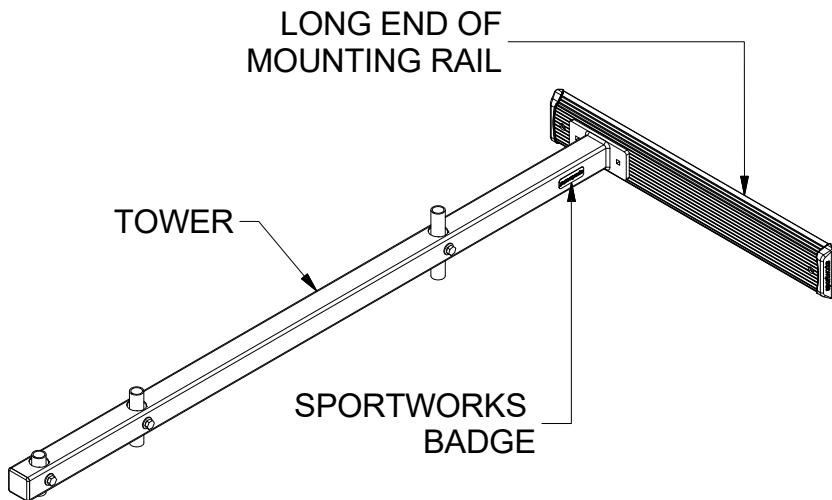

For single-sided racks, ensure the "Sportworks" badge on the tower faces the same direction as the long ends of the mounting rail.

The "Sportworks" badge indicates the front of the tower.

Orientation for double-sided racks is covered in Step 4.

STEP 3

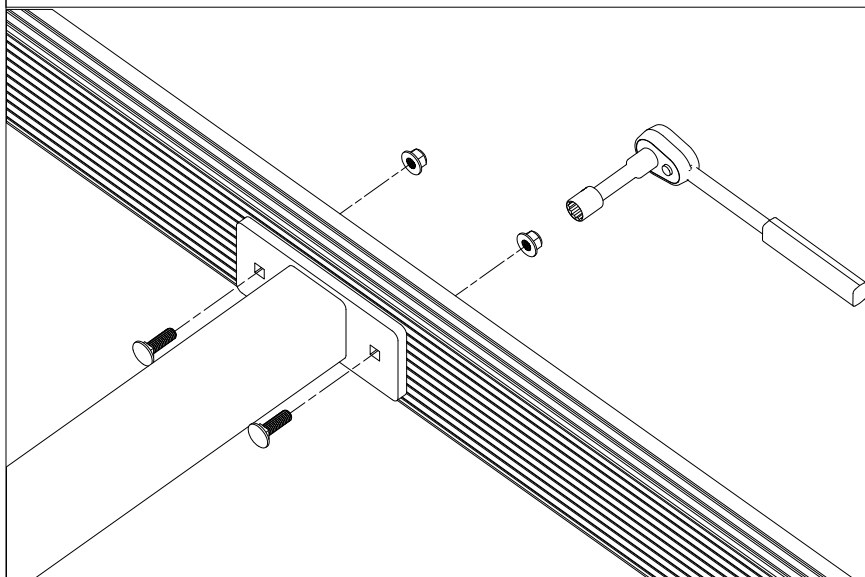

Bolt mounting rails to tower feet using carriage bolts and flanged hex nuts. Tighten nuts with a 9/16" socket and ratchet.

STEP 4

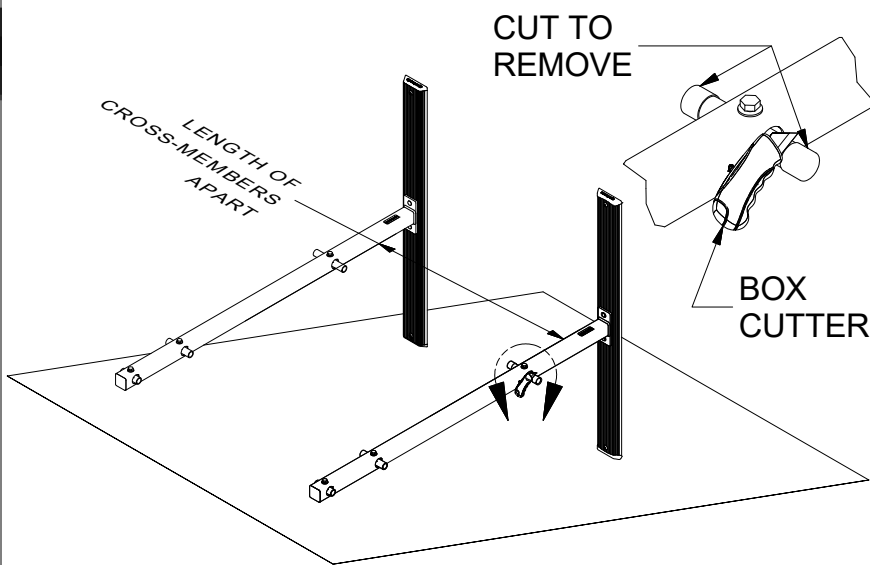

Lay both towers as shown making sure to space them approximately the length of the cross-members apart. Ensure sides of both towers with hex bolt heads and "Sportworks" badges are facing up.

If cross-members are to be shortened, refer to Step 2 of Section 4.

Then remove red plastic caps from pinch tube ends on all uprights with a box cutter as shown.

STEP 5

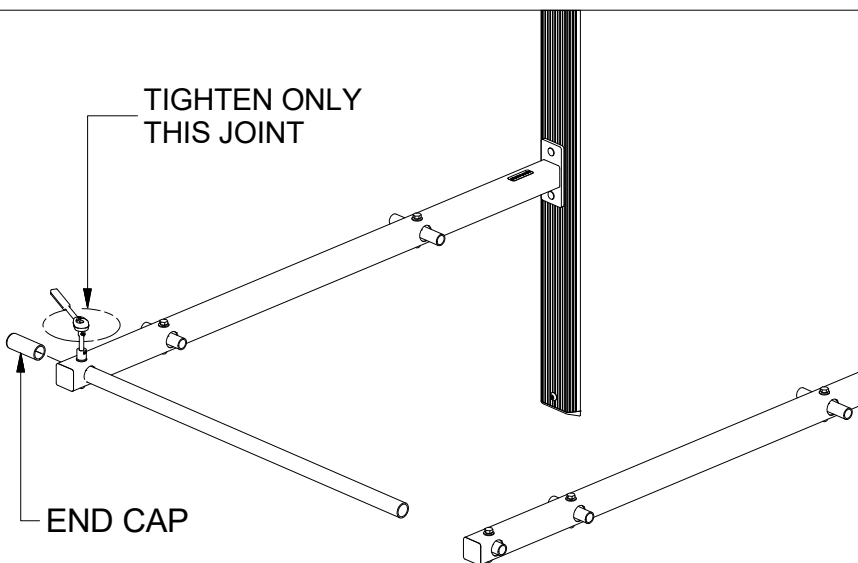

Insert only one cross-member into the one tower as shown. Start at the top of the tower. Ensure the cross-member is as far into the tower as it can go. Insert the end cap in the other side and tighten the joint with a 3/4" socket and ratchet.

STEP 6

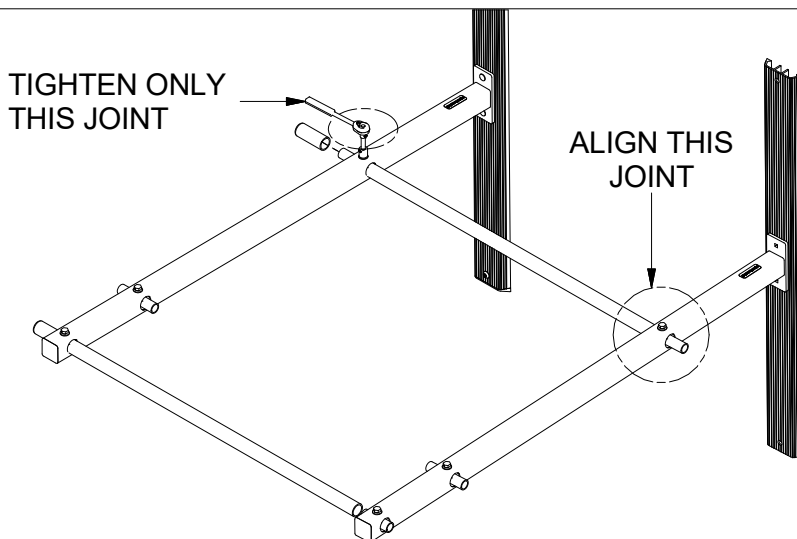

Insert lower cross-member into both towers as shown, then insert endcap into left hand tower joint and tighten only this joint.

Do not tighten the right hand side tower joint, you will need to leave this loose in order to get the last cross-member in.

STEP 7

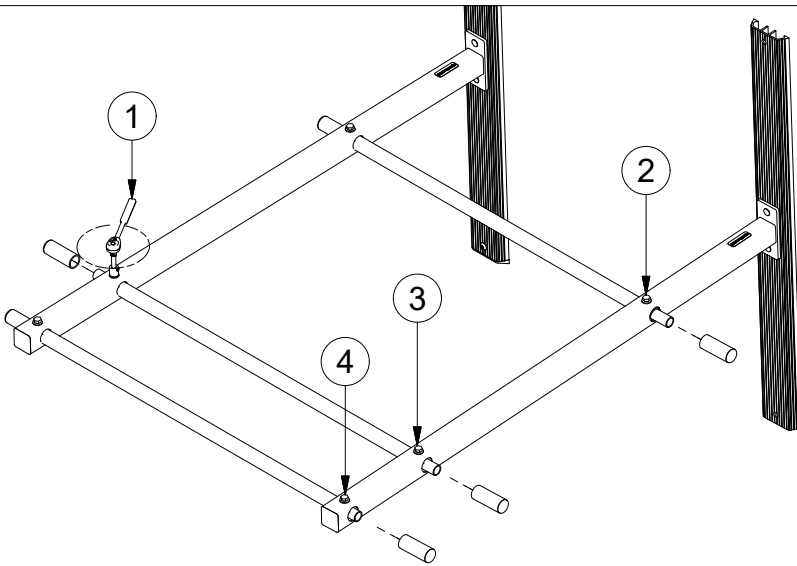

Insert middle cross-member into both towers as shown, then insert end cap into left hand tower joint and tighten.

Insert all opposite ends of cross-members into right hand tower joints. Ensure they are all inserted in as far as they will go. Insert remaining end caps and tighten all joints as indicated.

STEP 8

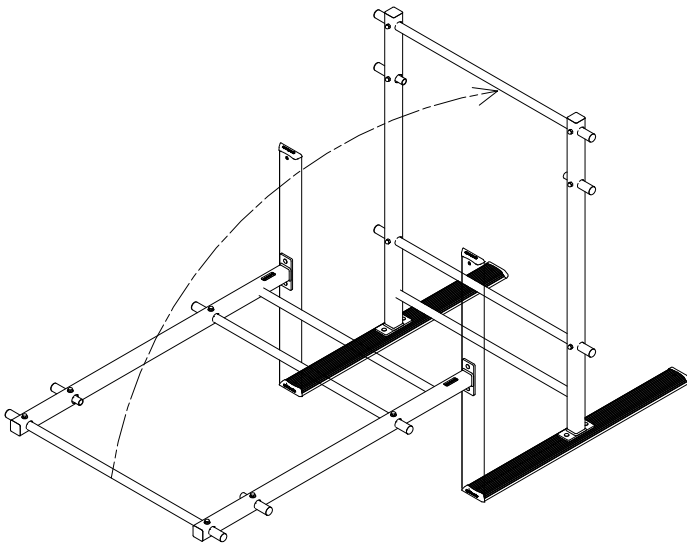

Tip assembled mounting structure upright by lifting the cross-member closest to the tops of the towers.

STEP 9

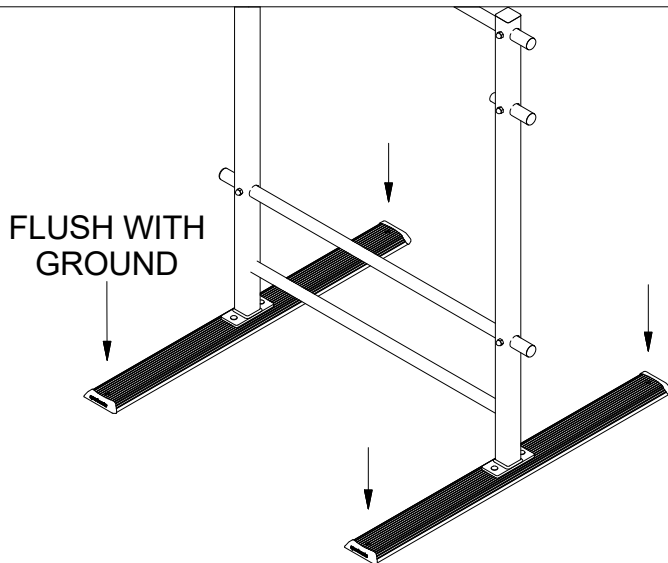

Check to make sure mounting rails sit flush on the ground and that all fasteners are tight.

If rails do not sit flush on ground, carefully loosen all tower joints and check to ensure all ends of cross-members are as far in as possible, then retighten all joints.

SECTION 2 - INSTALLING BICYCLE SUPPORTS

STEP 1

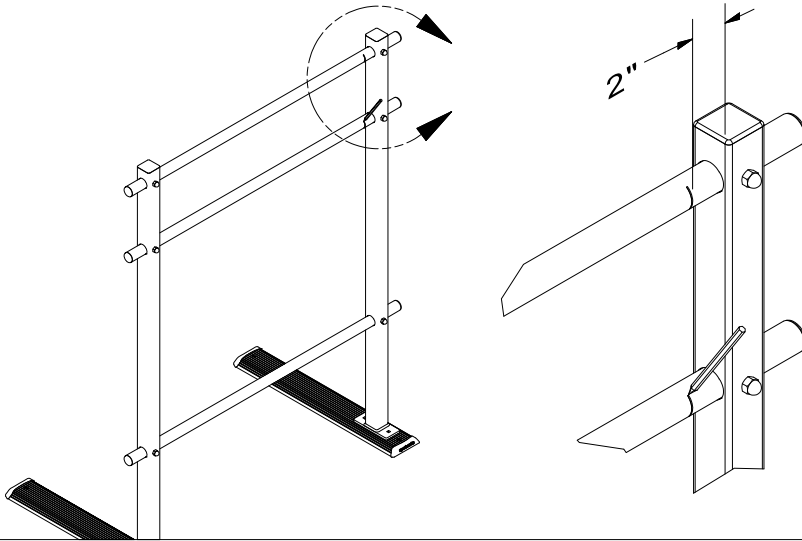

Mark the first bicycle mount location/s using a tape measure and a felt pen, starting from the right, mark the first bicycle mount location on the two upper cross-members 2" to the left from the inside edge of the right tower.

For single-sided racks, mark on the opposite side from the long ends of the mounting rails.

For double-sided racks, repeat this step for the reverse side of the two upper cross-members. Make sure to start from the right.

STEP 2

To determine the correct spacing between bicycle mounts, measure the distance between the inside edges of the uprights with a tape measure (see diagram in Step 3). Match the distance between uprights to that shown in the table below to determine spacing.

CROSS-MEMBER PART NUMBER:	DISTANCE BETWEEN UPRIGHTS ("):	SPACING BETWEEN BICYCLE MOUNTS ("):	# OF BIKE MOUNTS - SINGLE-SIDED:	# OF BIKE MOUNTS - DOUBLE-SIDED:
300303(-0006)	45.5	16	3	6
300304(-0006)	77.5	16	5	10
300305(-0006)	109.5	16	7	14
300307(-0006)	49.5	13	4	8
300308(-0006)	75.5	13	6	12
300309(-0006)	114.5	13	9	18
300318(-0006)	71.5	18	4	8
300319(-0006)	125.5	18	7	14

Note: Cross-member length = distance between uprights plus 2".

STEP 3

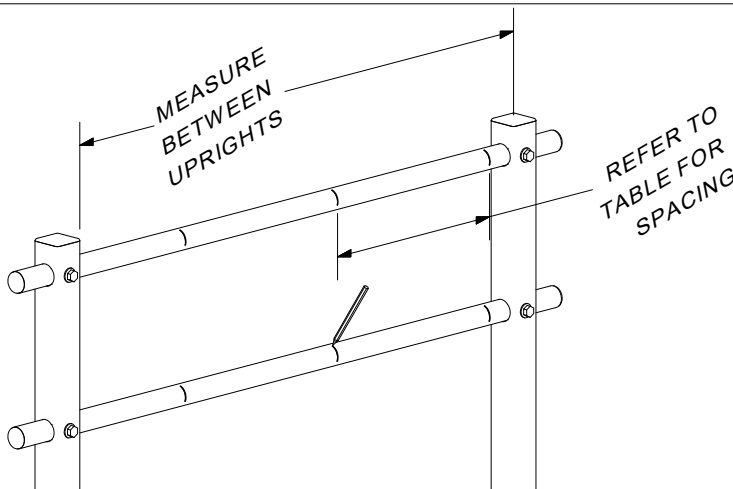

Mark the remaining bicycle mount locations by measuring from the first two 2" marks you made. Refer to the table above to determine the correct bicycle mount spacing. Put a mark on both upper cross-members for each bicycle mount.

For double-sided racks, repeat this step for the reverse side.

For spacing other than 13" or 16" between bikes, refer to Step 3 of Section 4 now.

STEP 4

(a)

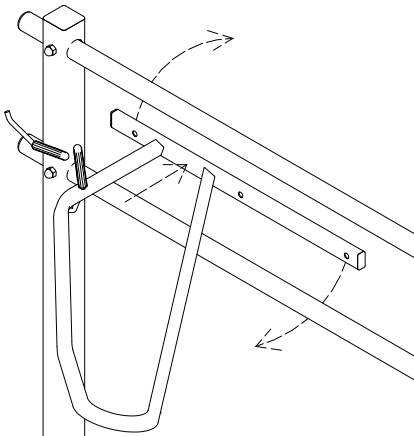

(b)

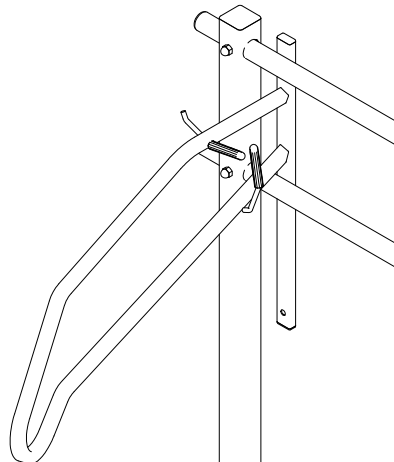

Starting from the left, place the first bicycle mount in the lower position by orienting horizontally to put the rectangular tube portion of the mount behind the cross-members as shown in (a). Then rotate the bicycle mount vertically again and allow it to rest against the cross-members as shown in (b).

For more high versus low position bike mounts, refer to Step 4 of Section 4.

STEP 5

(a)

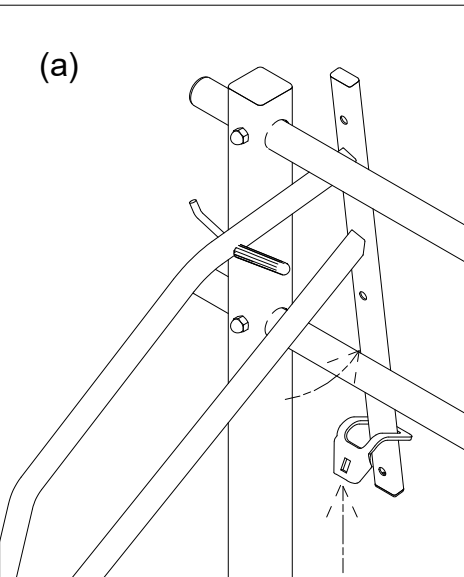

(b)

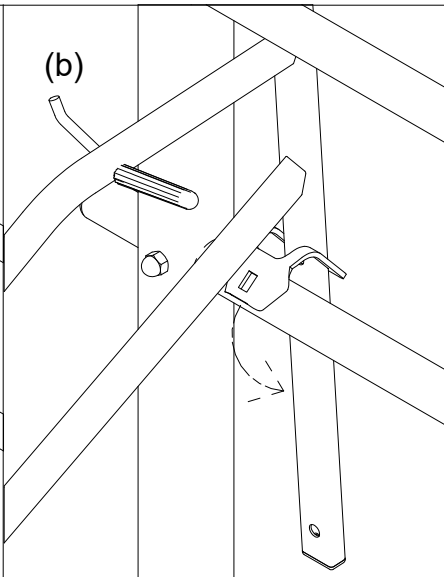

To position the first clamp, slide it up the rectangular tube as shown in (a). Push the bicycle mount back and up so the clamp can clear the middle cross-member. Then hook the clamp around this cross-member as shown in (b).

If you have the optional security cables for this rack, please refer to the assembly instructions that came with the security cables now.

STEP 6

(a)

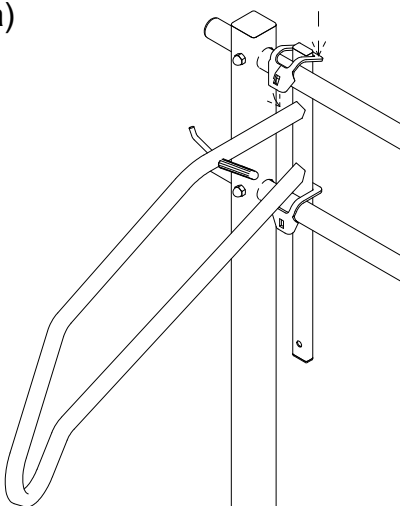

(b)

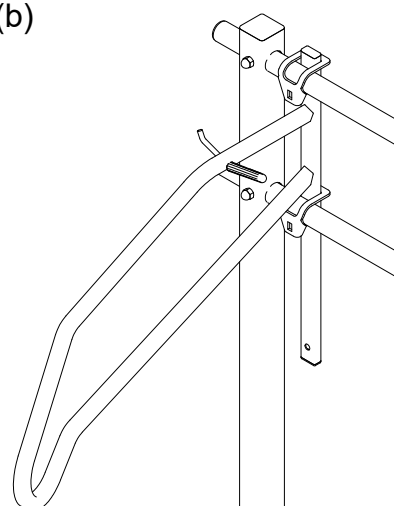

Position the second clamp by sliding down the rectangular tube and around the upper cross-member as shown in (a). Let clamp rest around the cross-member as shown in (b).

STEP 7

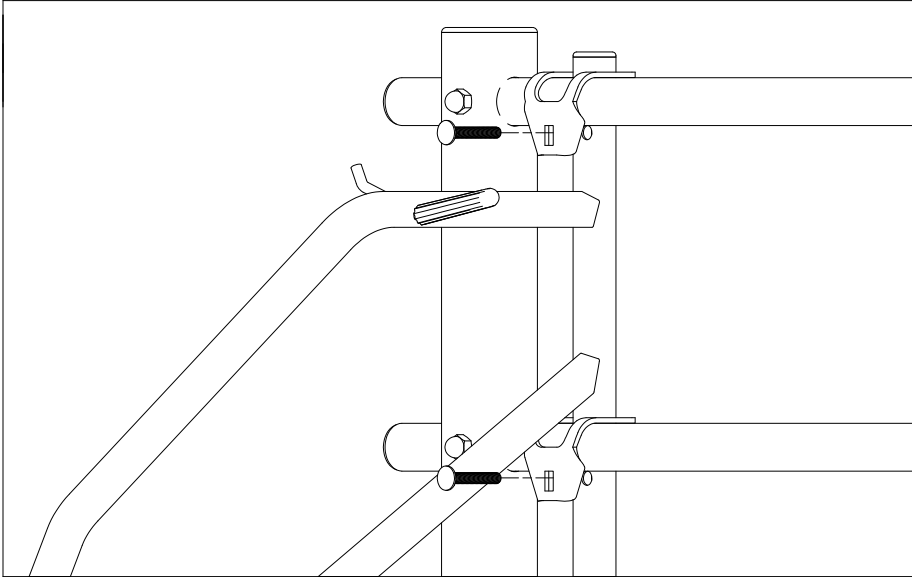

Place a carriage bolt through each of the square slotted holes in the front of the two clamps and into the corresponding holes in the front of the vertical tube of the bicycle mount as shown.

STEP 8

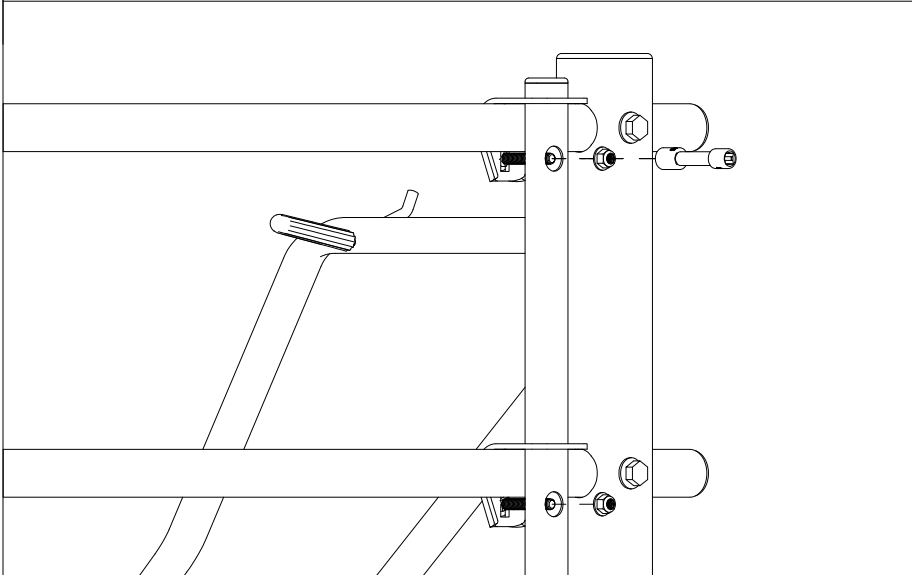

Using a 9/16" socket, place a locking flanged hex nut into the socket, then insert the nut through the corresponding hole in the back of the rectangular tube and thread the nut onto the carriage bolt. Repeat for the second carriage bolt. Thread the nuts until the locking portion of the nut is reached.

Hand tighten only.

STEP 9

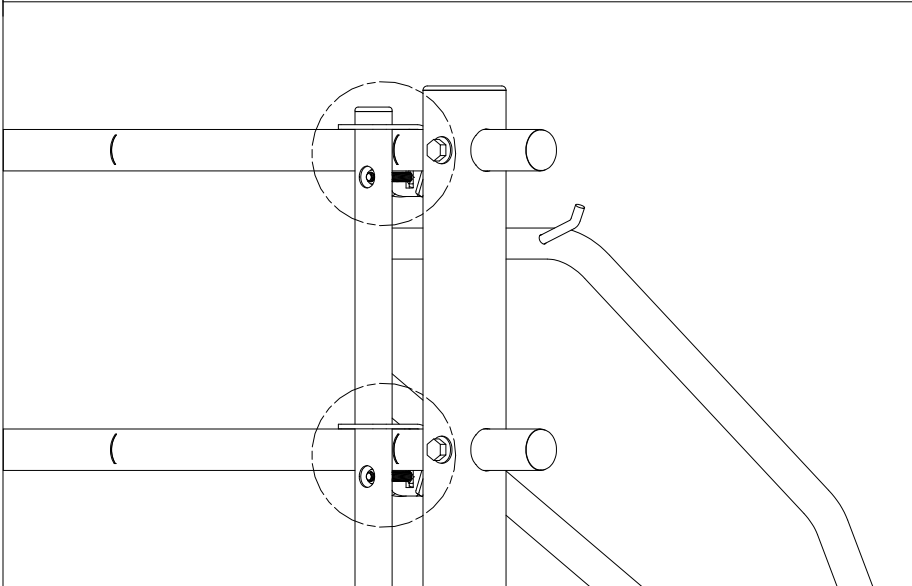

Align the left hand edge of the bicycle mounts rectangular tube with the first two marks (on the two upper cross-members) you made in Step 1, then tighten both flanged hex nuts.

STEP 10

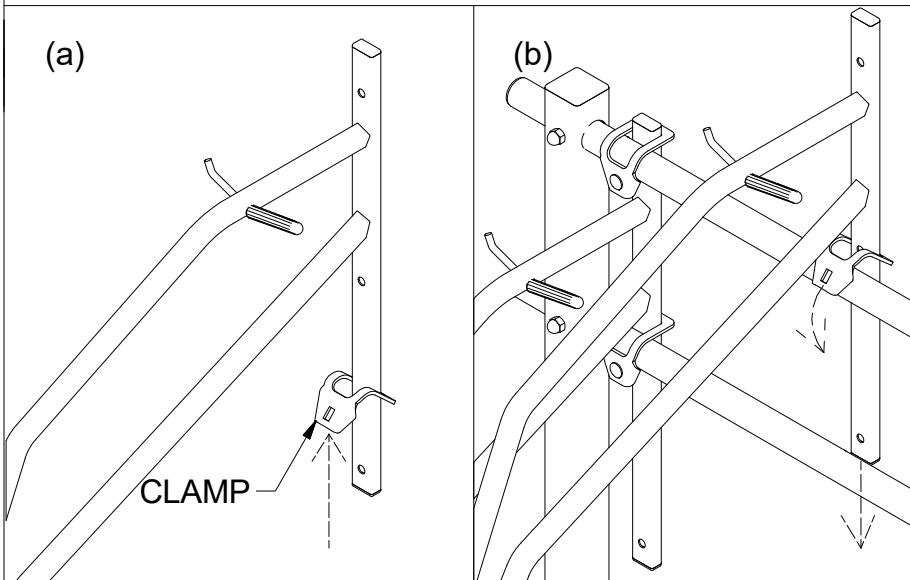

Before installing the next bicycle mount in the upper position, slide a clamp up the rectangular tube as shown in (a). Ensure the rectangular tube portion of the mount is positioned behind the cross-members and hook the clamp over the top of the upper most cross-member as shown in (b).

STEP 11

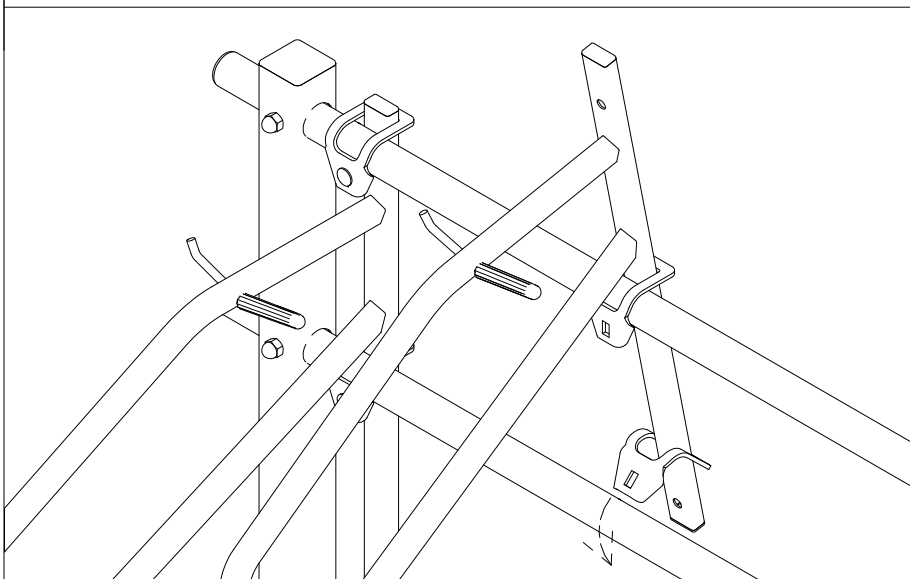

Position the second clamp by sliding up the rectangular tube. Push the lower portion of the rectangular tube back so the clamp can be hooked around the middle cross-member as shown. Then repeat Steps 7 and 8.

STEP 12

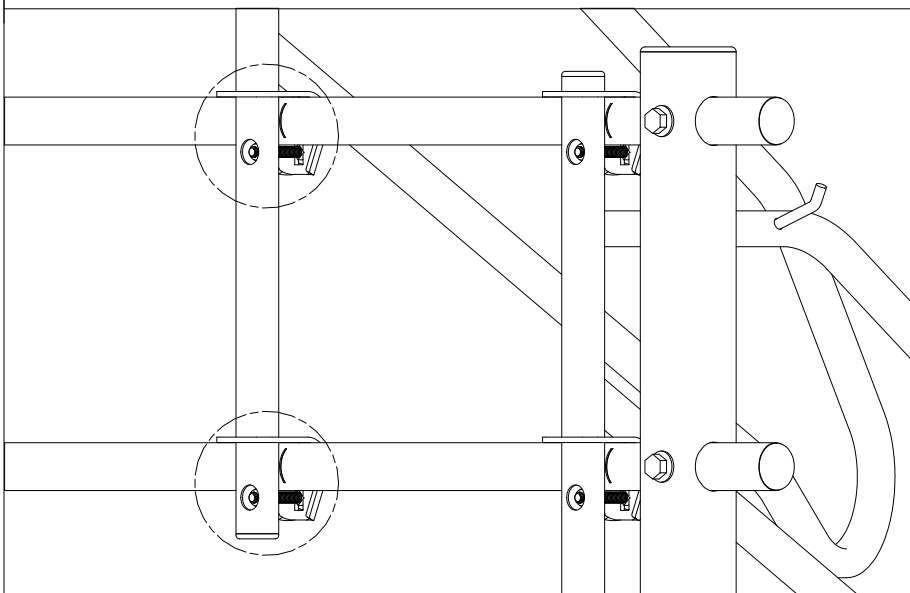

Align the left hand edge of the bicycle mounts rectangular tube with the next set of markings you made in Step 3, then tighten both flanged hex nuts.

STEP 13

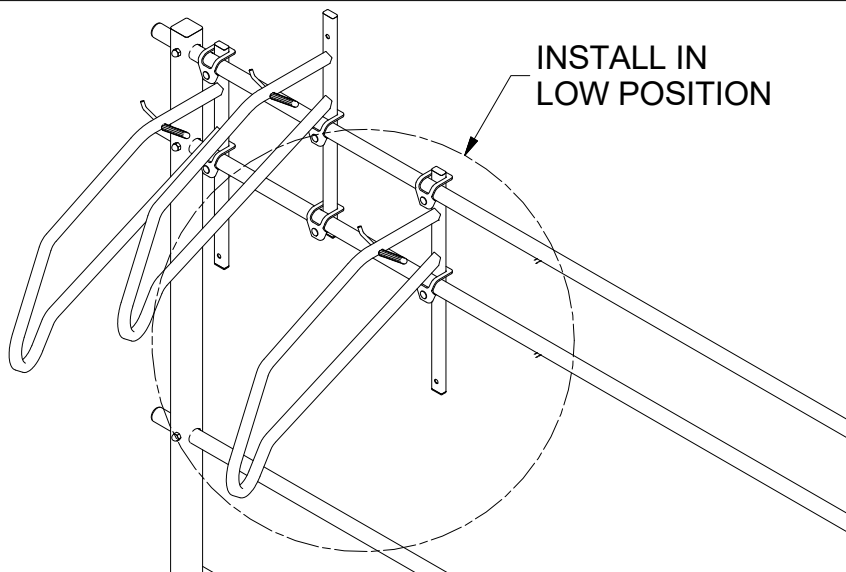

Install the next bicycle mount in the lower position following Steps 4, 5, 6, 7, 8 and 12.

STEP 14

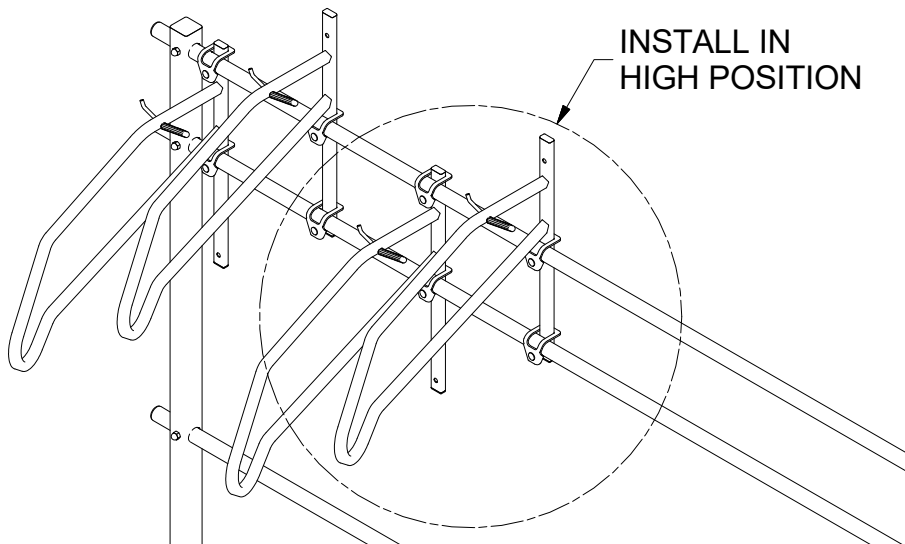

Install the next bicycle mount in the upper position following Steps 10, 11 and 12.

STEP 15

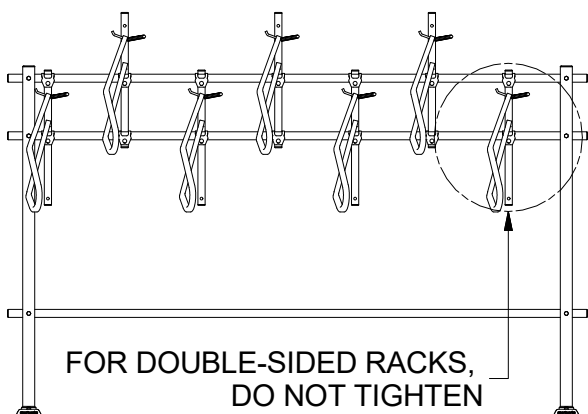

Continue to follow Steps 13 and 14 until all bicycle mounts have been installed and each is alternating in height (low, high, low, high, etc.).

For double-sided racks only, leave this last bicycle mount untightened (see Step 16).

STEP 16

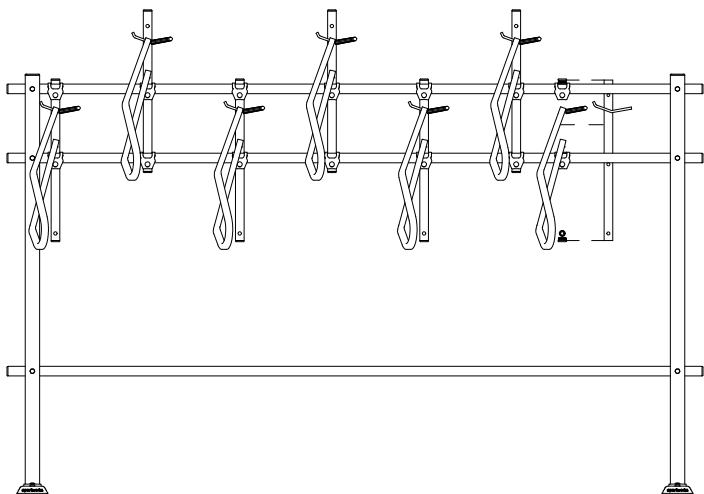

For single-sided racks, go to Step 20.

Move the last bicycle mount you installed in Step 15 away from the right hand tower as shown. This will create a temporary gap when installing the first bicycle mount for the reverse side of the rack.

STEP 17

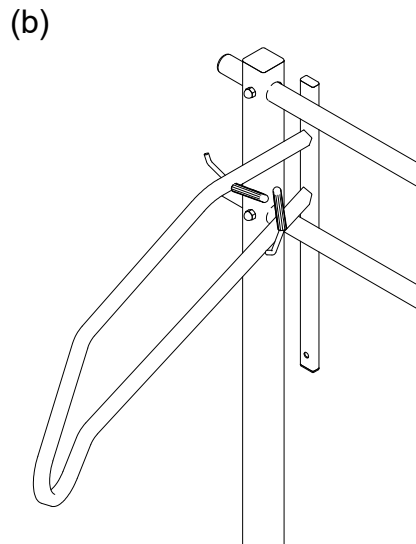
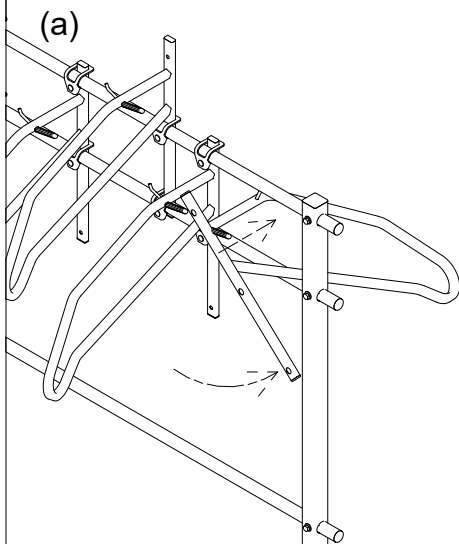

Place the first bicycle mount in the low position for the reverse side of the rack, by orienting diagonally and inserting between the two upper cross-members and through the gap you just created, as shown in (b). Then rotate the bicycle mount vertically again and allow it to rest against the cross-members as shown in (b).

STEP 18

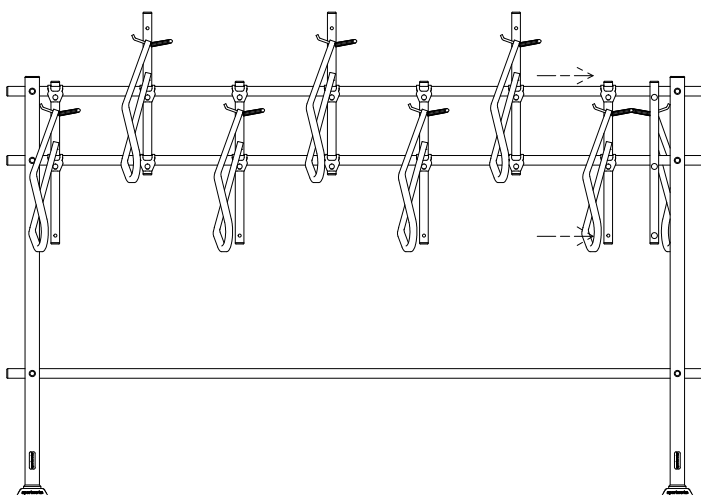

Slide the bicycle mount back that you moved in Step 16. Align the left hand edge of the bicycle mounts rectangular tube with the marks you made in Step 3, then tighten both flanged hex nuts.

STEP 19

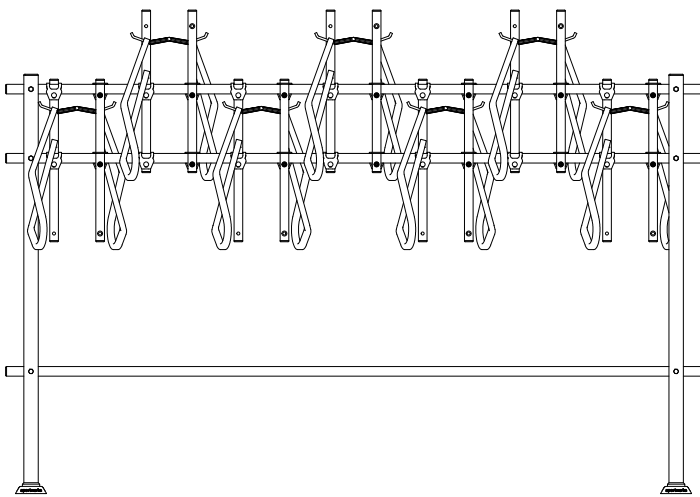

Continue to follow Steps 4 to 15 on the reverse side of the rack until all bicycle mounts are installed.

Ensure all flanged hex nuts are tight before moving on to Step 20.

STEP 20

To increase the security of the rack, the shown security rings can be installed in two different ways to achieve varying levels of security (for security ring guidelines and removal, see Step 1 of Section 4). Select your desired level of security and install as shown:

(a) SECURITY RING

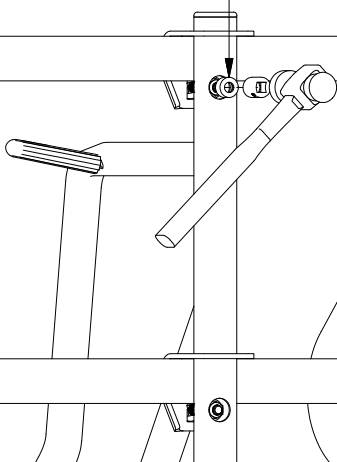

(b)

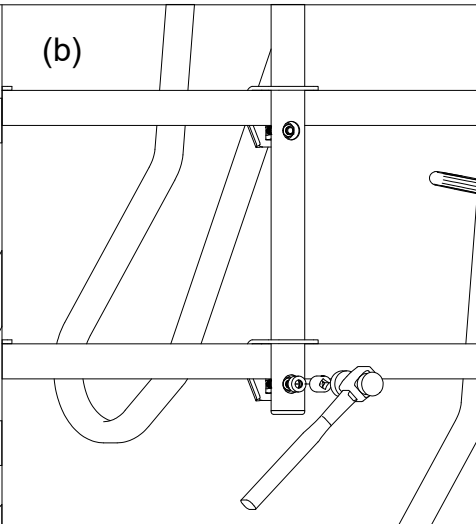

For **MEDIUM** security, use a 9/16" socket and a hammer to tap a security ring around the locking flanged hex nut of the upper clamp for each bicycle mount in the lower position as shown in (a), and the lower clamp for each bicycle mount in the upper position as shown in (b).

(a)

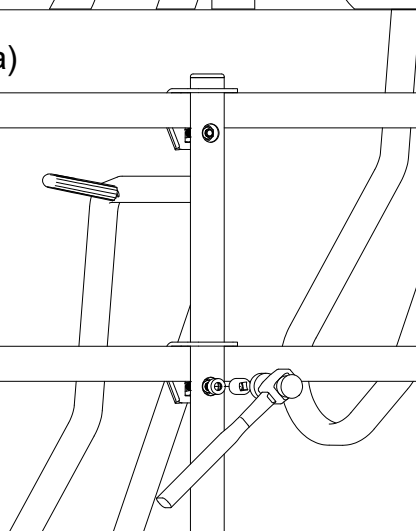

(b)

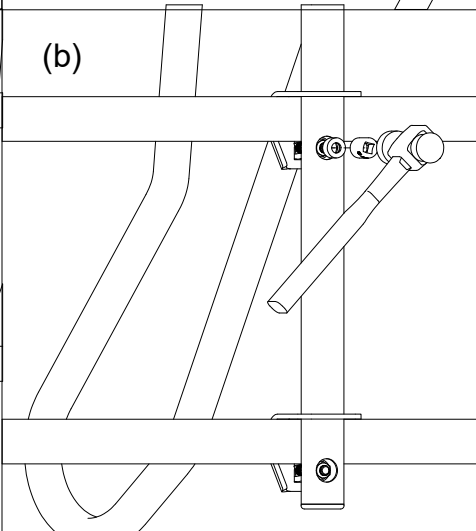

For **HIGH** security, use a 9/16" socket and a hammer to tap a security ring around the locking flanged hex nut of the lower clamp for each bicycle mount in the lower position as shown in (a), and the upper clamp for each bicycle mount in the upper position as shown in (b).

STEP 21

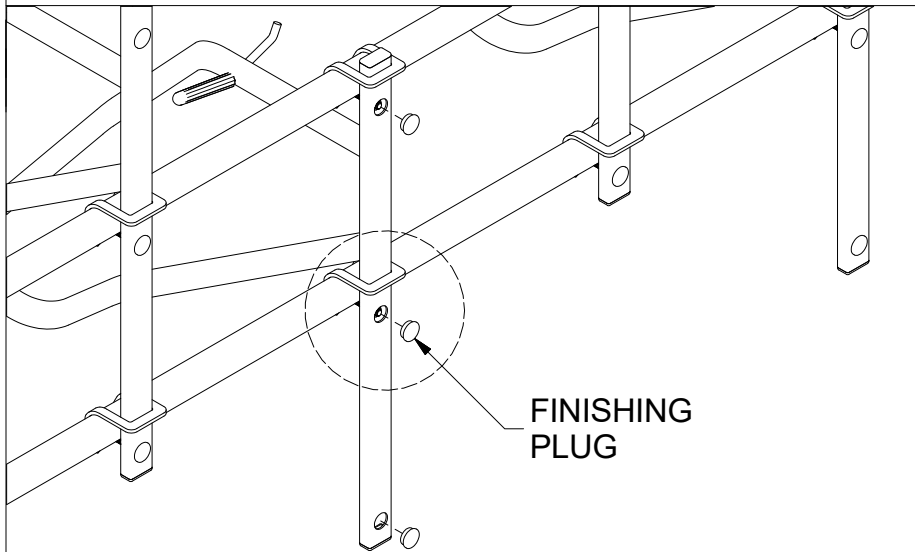

Install larger finishing plugs in all three holes in the back of each bicycle mount as shown.

STEP 22

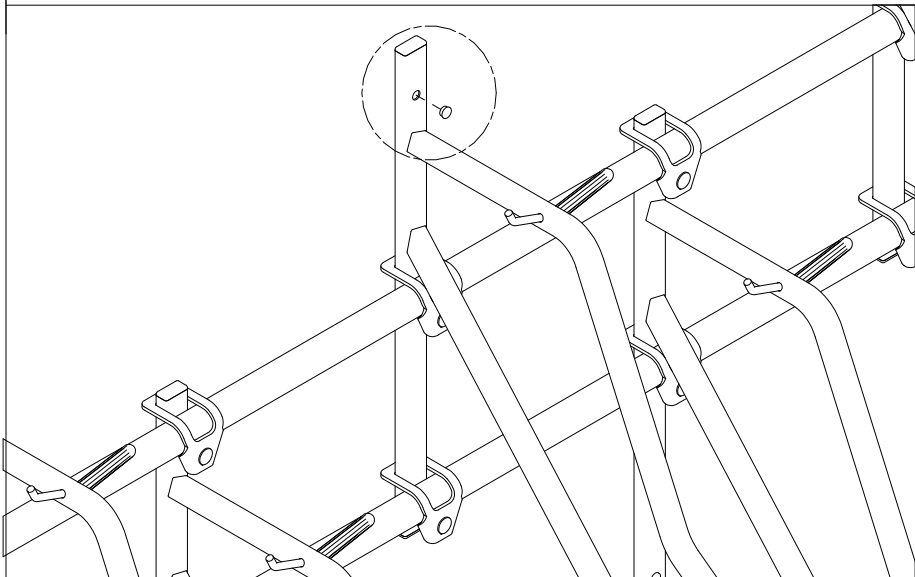

Install smaller finishing plugs in each hole in the front of each bicycle mount as shown.

SECTION 3 - ADDING SECTIONS

STEP 1

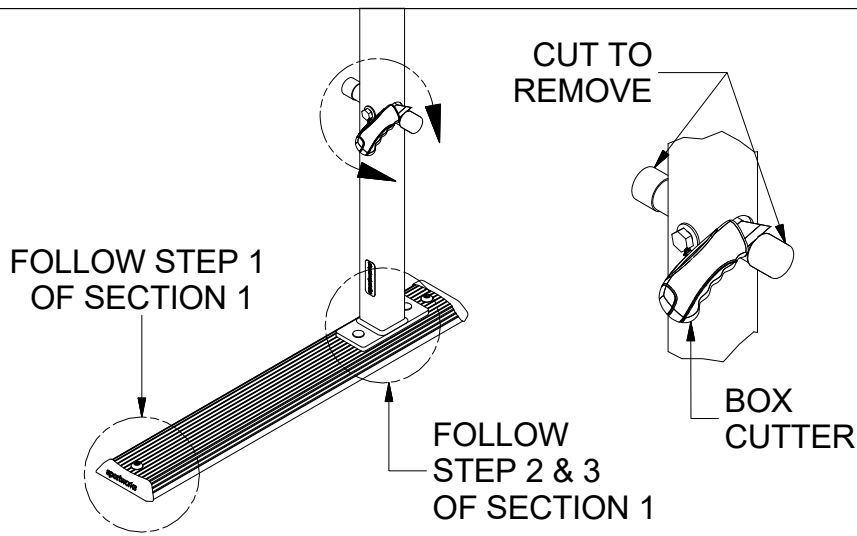

Assemble new tower following Steps 1, 2 and 3 of Section 1 (see Page 1).

Then remove red plastic caps from pinch tube ends on all uprights with a box cutter as shown.

STEP 2

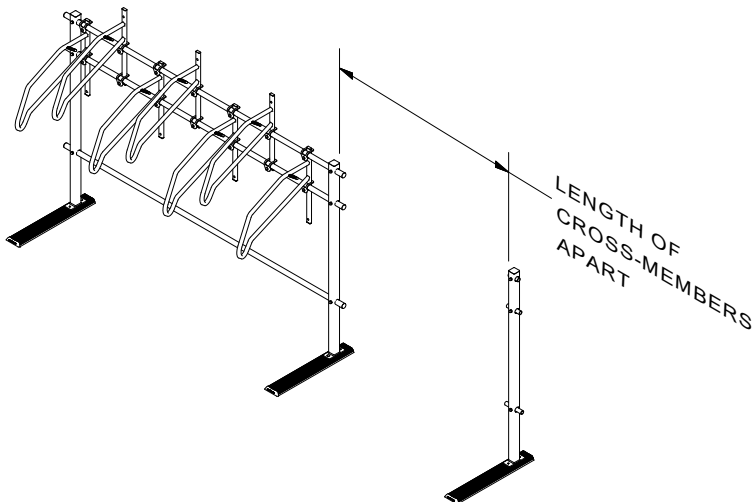

Stand new tower up spacing it approximately the length of the cross-members apart from the existing section. Ensure the hex bolt heads face the same direction as on the existing towers.

STEP 3

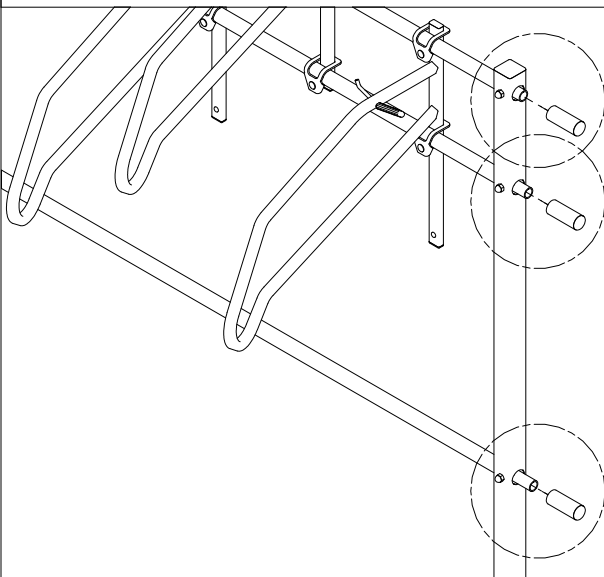

Loosen all three joints of the existing tower and remove the three endcaps.

STEP 4

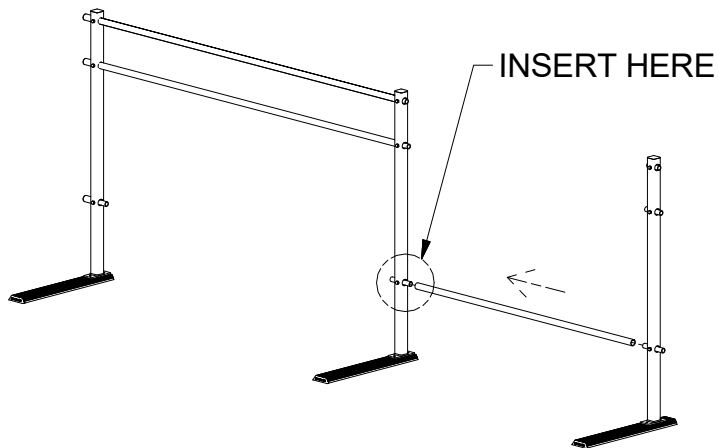

While supporting the full length of the cross-member, insert one end into the low joint of the existing tower. Ensure this end of the cross-members is as far into the tower as it will go.

STEP 5

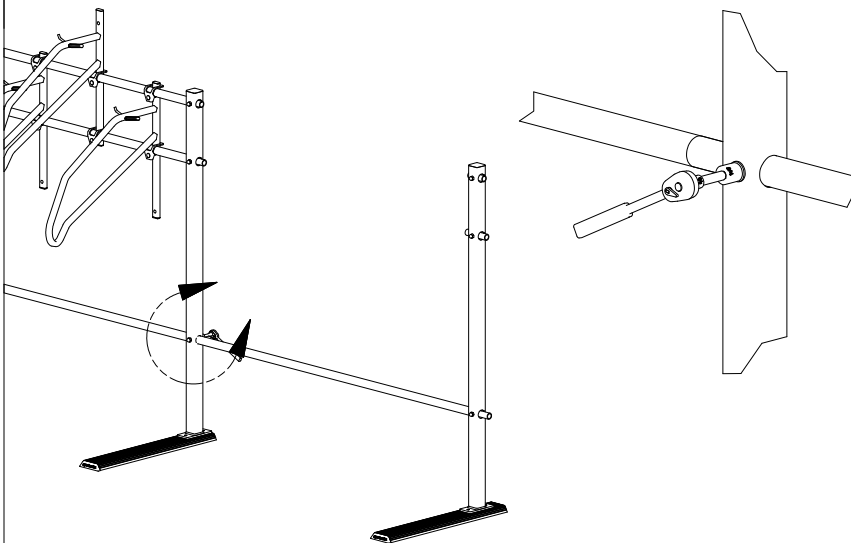

Install the opposite end of the cross-member into the low joint of the new tower. Ensure both ends of the cross-members are as far into both towers as they will go. Tighten only the low joint of the existing tower.

Note per prior instructions, the hex bolt heads will be facing the same direction as the long side of the single-sided feet.

STEP 6

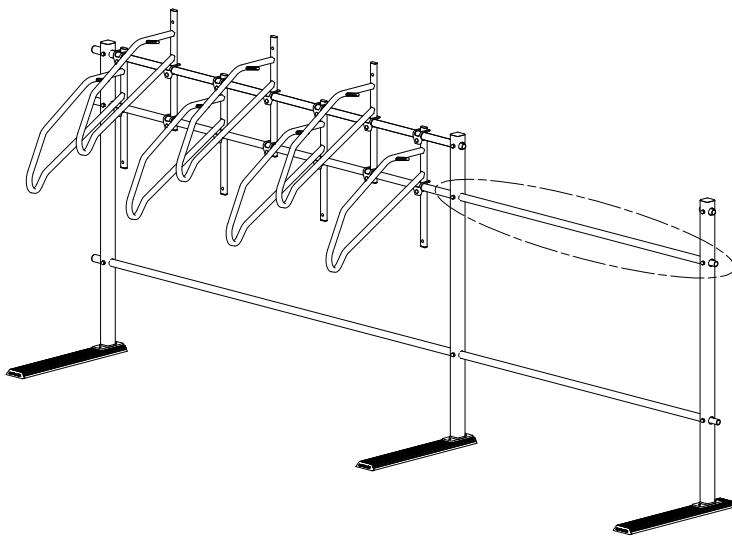

Install the second cross-member by repeating Steps 4 and 5, this time installing it into the middle joint.

STEP 7

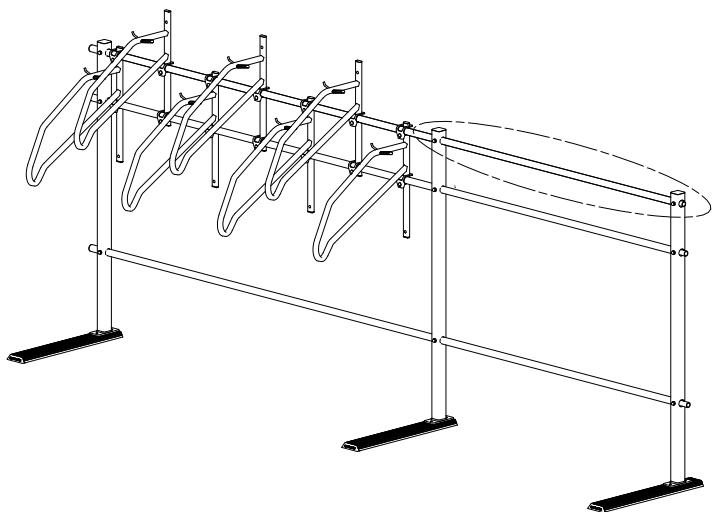

Install the third cross-member by repeating Steps 4 and 5, this time installing it into the high joint.

STEP 8

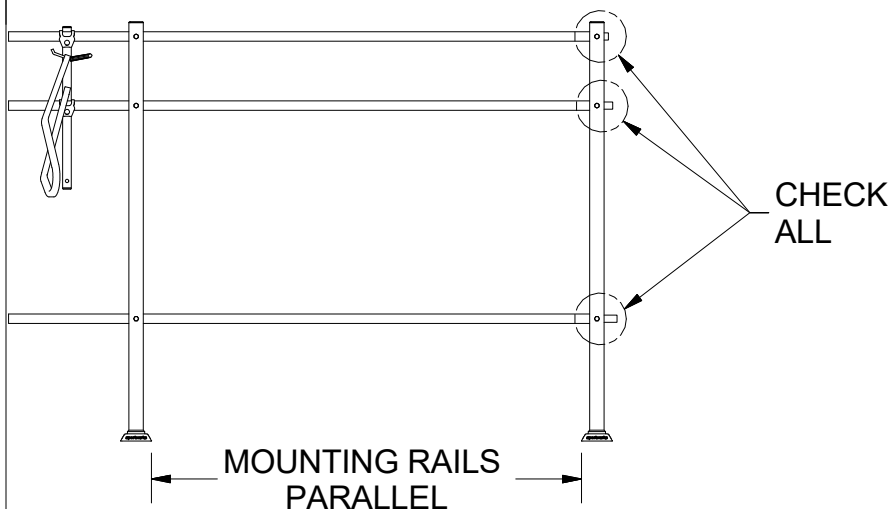

Double check that all of the untightened cross-member ends are as far into the new tower as they will go and that the new mounting rails are parallel with the existing towers mounting rails.

STEP 9

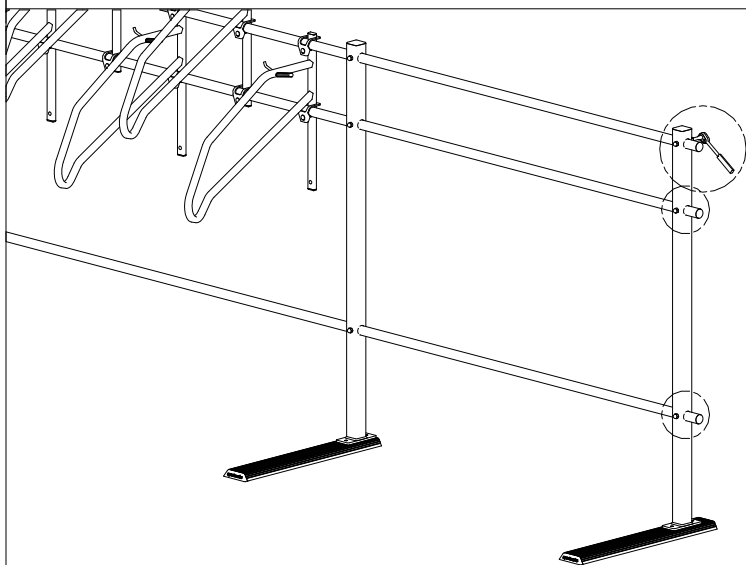

If you have another section to install repeat steps 1 through 8. If not, install the three end caps and tighten the new joints.

STEP 10

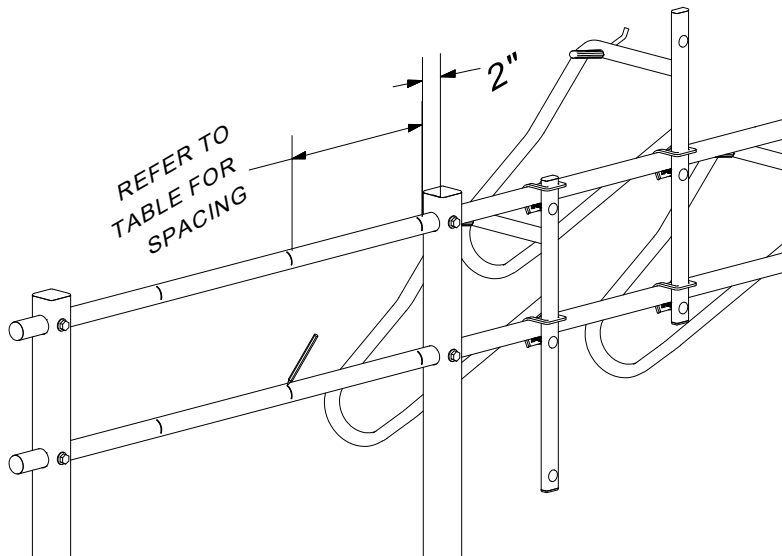

Mark bicycle mount locations for the new section/s by following Steps 1, 2 and 3 of Section 2.

STEP 11

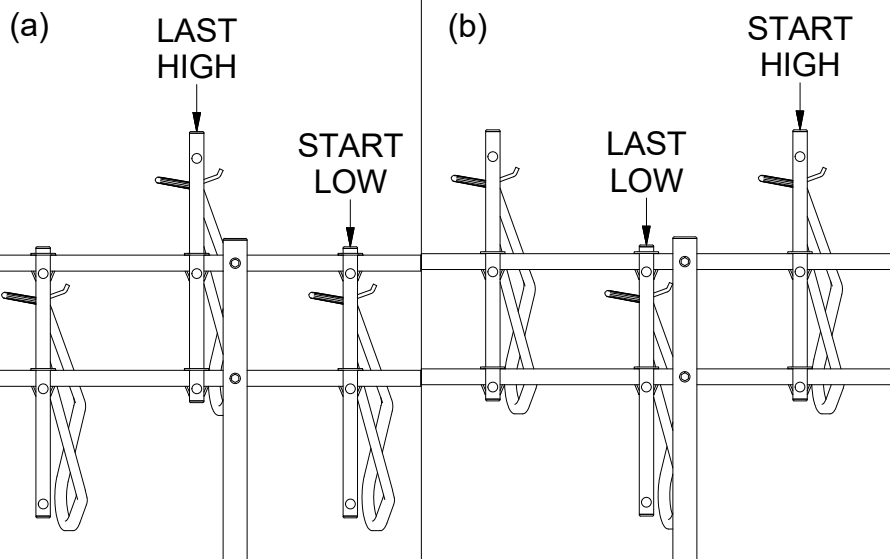

Identify if the last bicycle mount in the preceding section is in the high position, shown in (a), or in the low position, shown in (b).

If the last bicycle mount is in the low position start in the high position following Steps 10, 11 and 12 of Section 2.

Alternatively, if the last bicycle mount is in the high position start in the low position by following Steps 4 through 9 of Section 2.

STEP 12

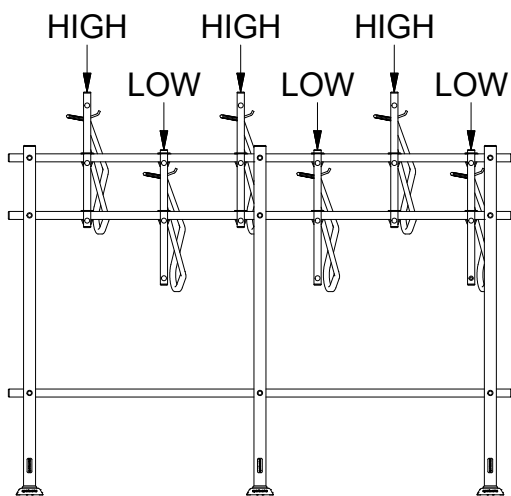

Continue installing bicycle mounts following Steps 13 through 22 of Section 2, ensuring that each bicycle mount is alternating in height.

For every new section, make sure to start installing bicycle mounts in the opposite position of the last.

All bicycle mounts should be alternating in height.

SECTION 4 - CUSTOMIZING RACK COFIGURATION

STEP 1 - Security Ring: Guidelines and Removal

MEDIUM LEVEL: Intended for installations in secure areas where access is controlled by a combination lock or key card entry point/s. This level of security is also intended for situations where the rack may need to be relocated and/or reconfigured. An easy method of removing the security ring is shown below.

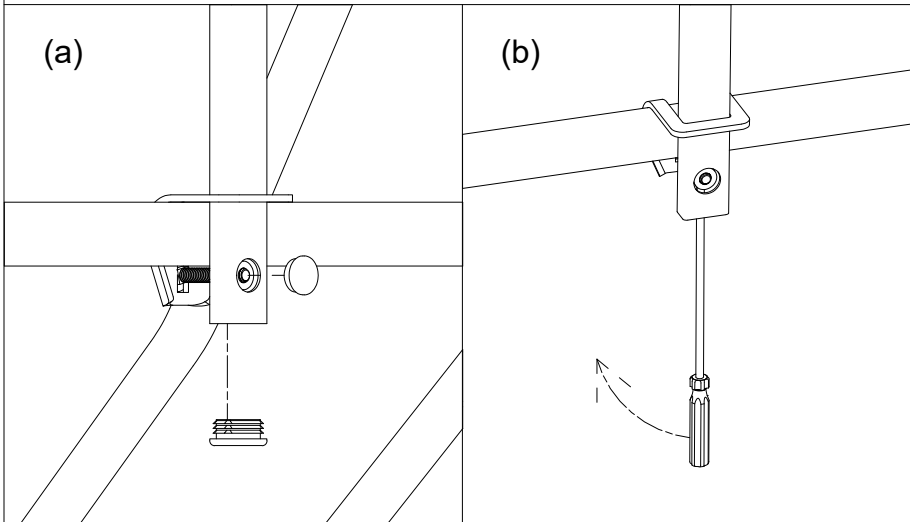

Start by removing the rectangular endcap in the end of the bike mount closest to the security ring and the round endcap hiding the security ring, as shown in (a).

Insert a screw driver between the security ring and surface of the flanged hex nut as shown in (b), then lever it off.

HIGH LEVEL: Intended for installations in less secure areas where access is not controlled. This level of security is also intended for situations where it is very unlikely the rack will need to be relocated and/or reconfigured. Although no easy method of removing the security ring is available, a method is shown below.

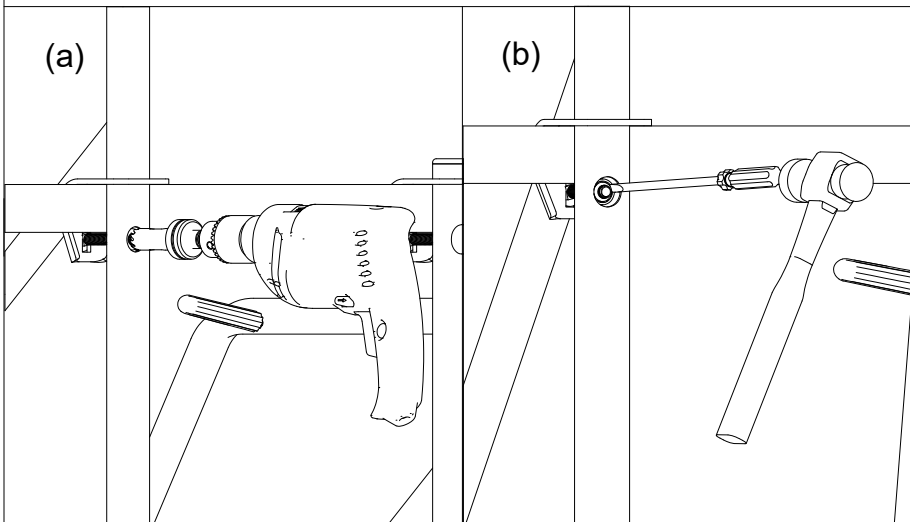

Start by removing the round endcap hiding the security ring.

Use a 3/4" hole saw (with the pilot drill removed) and a drill to drill the flat face away from the security ring as shown in (a).

Insert a screw driver between the security ring and the flat of the flanged hex nut, hit the screw driver with a hammer until the remaining portion of the security ring breaks, then remove it.

STEP 2 - Shortening Cross-Members

All cross-members are galvanized 1.25" Schedule 40 pipe, and can be easily shortened to a desired length. It is recommended that cross-members are shortened in 13" or 16" increments to preserve bicycle spacing. Typically, for every 13 or 16" length that is removed, one bicycle mount on each side is also removed. It is best to shorten cross-members prior to assembly, however, if the rack has already been assembled, disassemble the rack to get access to the cross-members by following Step 7 of Section 4.

STEP 3 - Reducing or Increasing Bike-to-Bike Spacing

Horizontal spacing between bicycles can be altered to either reduce or increase bike parking capacity. This is easily achieved by loosening the locking flanged hex nuts of the bike mount clamps and sliding the bike mounts closer together or further apart. 16" spacing is the best compromise between usability and density. Spacing as low as 13" has worked for some users.

STEP 4 - Altering High versus Low Position Bike Mounts

The standard rack installation renders more bike mounts in the low position, this is because most people prefer not to lift their bicycles higher than they need to (see Page 8, Step 15). In some situations it may be desirable to have more bike mounts in the high position (e.g. if most people have extremely long wheelbase bikes). To configure the rack to have more high position bike mounts follow the instructions below.

- | | |
|---|---|
| 1 | Instead of installing the first bike mount in the low position, install it in the high position, follow Steps 10, 11 and 12 of Section 2. |
| 2 | Install the next bike mount in the low position, follow Steps 4 to 9 of Section 2. |
| 3 | Continue to follow Steps 13 and 14 of Section 2 ensuring bicycle mounts are alternating in height (high, low, high, low, etc.). This installation sequence will render more bike mounts in the high position. |

STEP 5 - Changing from Single-Sided to Double-Sided

Any single-sided vertical rack can easily be changed to double-sided and typically requires the purchase of more bike mounts, Sportworks Part Number: 300306(-0027), and double-sided mounting rails, Sportworks Part Number: 300301(-0026).

- | | |
|---|--|
| 1 | Lay rack over as shown in Step 4 of Section 1. |
| 2 | Replace all the existing mounting rails with the double-sided mounting rails following Steps 1 and 2 of Section 1. |
| 3 | Tip rack upright and to check all new mounting rails sit flush on the ground following Steps 8 and 9 of Section 1. |
| 4 | Mark all bicycle mount location/s for the reverse side of the rack following Steps 1 to 3 of Section 2. |
| 5 | Install all bicycle mounts on the reverse side following Steps 1 through 22 of Section 2. |

STEP 6 - Changing from Double-Sided to Single-Sided

Any double-sided vertical rack can easily be changed to single-sided and requires the purchase of a single-sided mounting rails, Sportworks Part Number: 300302(-0026).

- | | |
|---|--|
| 1 | Remove all the bicycle mounts that face the opposite direction of the tower hex bolt heads. Start by remove the large finishing plugs on the back of the bicycle mounts to get access to the clamp locking flanged hex nuts. |
| 2 | Remove security rings if required by following Step 1 of Section 4. |
| 3 | Unscrew all of the clamp locking flanged hex nuts and remove bicycle mounts. |
| 4 | Lay rack over as shown in Step 4 of Section 1. |
| 5 | Replace all the existing mounting rails with the single-sided mounting rails following Steps 1 and 2 of Section 1. |

6	Tip rack upright and check all new mounting rails sit flush on the ground following Steps 8 and 9 of Section 1.
---	---

STEP 7 - Cross-Member Replacement

1	Remove all bicycle mounts. Start by removing the large finishing plugs on the back of the bicycle mounts to get access to the clamp locking flanged hex nuts.
2	Remove security rings if required by following Step 1 of Section 4.
3	Unscrew all of the clamp locking flanged hex nuts and remove bicycle mounts.
4	Lay rack over as shown in Step 4 of Section 1.
5	Loosen all tower joints and replace existing cross-members. Refer to Steps 5 to 7 of Section 1 for tower joint locations and tool recommendations.
6	Reassemble rack by following all assembly steps detailed in Sections 1 and 2.

