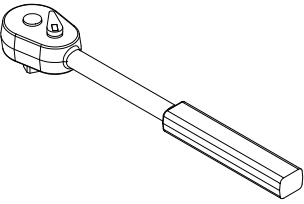
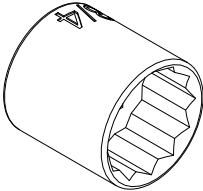
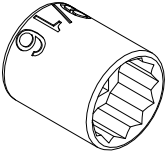
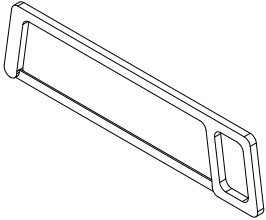
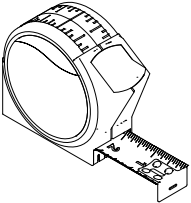
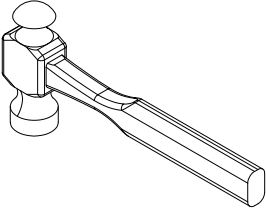
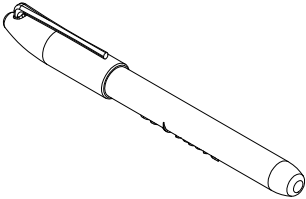

TABLE OF CONTENTS

SECTION	SECTION TITLE	PAGE NO.
1	Assembling Mounting Structure	1
2	Installing Bicycle Supports	2
3	Mounting Rack to Wall	9
4	Adding Sections	13
5	Customizing Rack Configuration	18

REQUIRED TOOLS



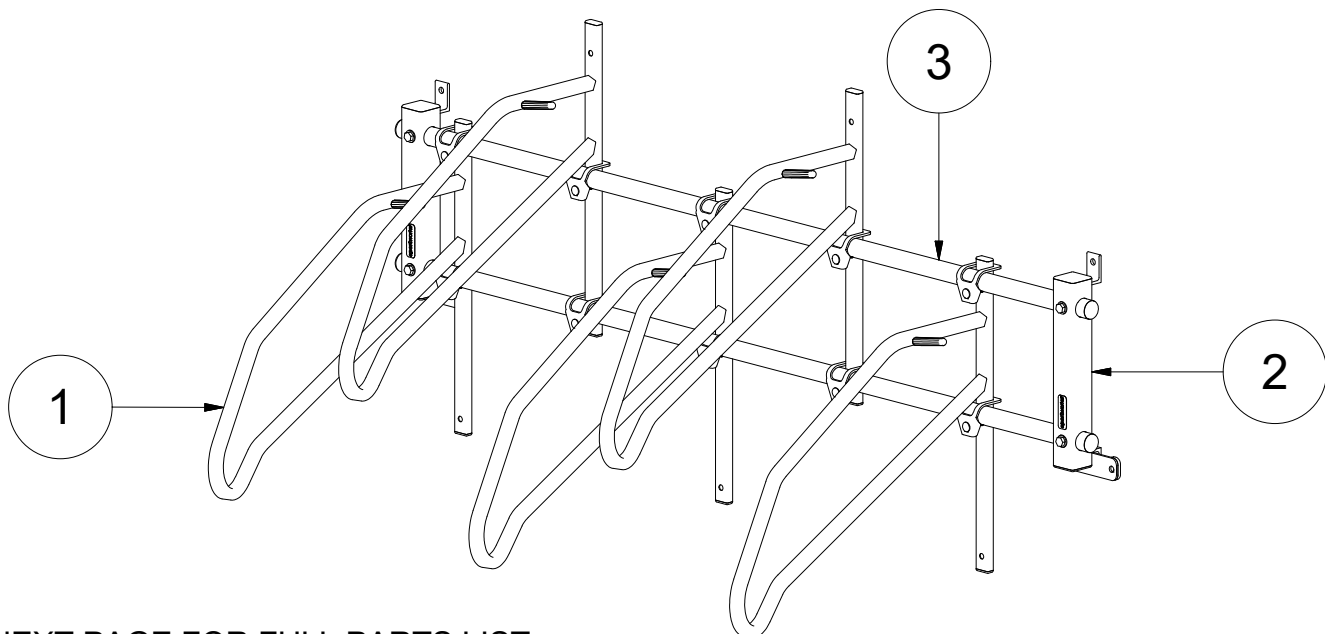

 RATCHET	 3/4" SOCKET	 9/16" SOCKET	<p>OPTIONAL ONLY NEEDED IF CROSS-MEMBERS ARE TO BE SHORTENED</p>  HACKSAW
 TAPE MEASURE	 HAMMER	 FELT PEN	

ASSEMBLY PARTS DIAGRAM

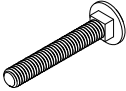

SEE NEXT PAGE FOR FULL PARTS LIST

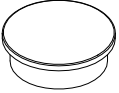
VERTICAL+ PARTS LIST

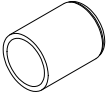
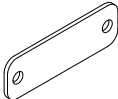
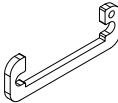
ITEM	DESCRIPTION	QTY PER
1	BIKE SUPPORT 300306(-XXXX)	1
	CLAMP	2
	CARRIAGE BOLT, 2.5" L.	2
	LOCKING FLANGED HEX NUT	2
	SECURITY RING	1
	LARGE FINISHING PLUG	3
	SMALL FINISHING PLUG	1
2	UPRIGHT 300310(-XXXX)	1
	ENDCAP	2
	FRONT WALL-MOUNT BRACKET	1
	BACK WALL-MOUNT BRACKET	1
3	CROSS-MEMBERS 300312(-XXXX), 300313(-XXXX), 300314(-XXXX), 300315(-XXXX), 300316(-XXXX), 300317(-XXXX), 300320(-XXXX) and 300321(-XXXX)	2

SECTION 1 - ASSEMBLING MOUNTING STRUCTURE

SECTION 1 - STEP 1

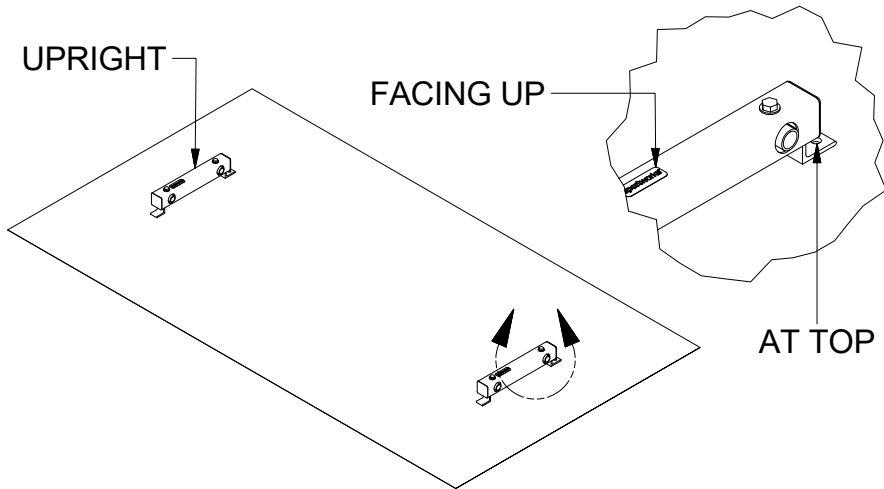

Place both uprights on the floor as shown approximately the width of the cross-members apart. Ensure the Sportworks decals are facing up and the L-brackets with the holes are at the top.

SECTION 1 - STEP 2

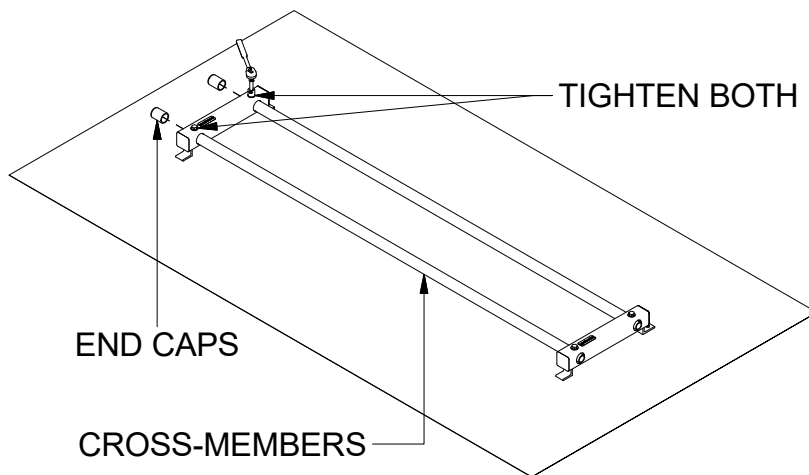

Install one end of both cross-members into one upright as shown. Ensure the cross-members are as far into the upright as they can go.

Install end caps as shown and tighten both joints with a 3/4" socket and ratchet.

SECTION 1 - STEP 3

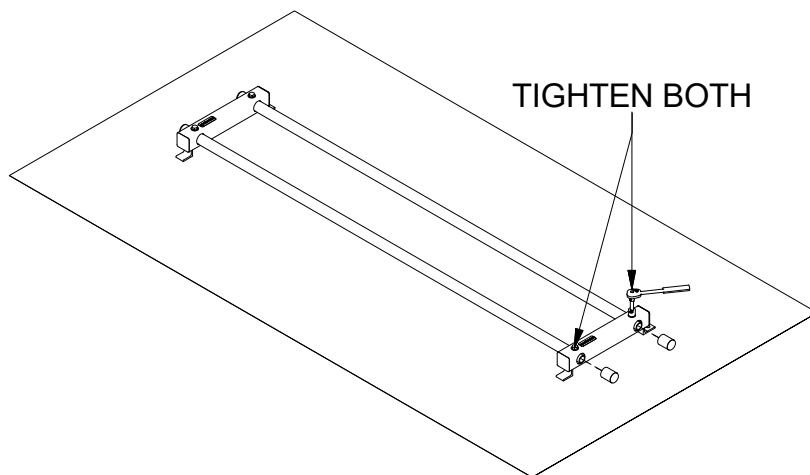

Insert opposite ends of cross-members into the second upright, then install end caps and tighten both joints.

SECTION 2 - INSTALLING BICYCLE SUPPORTS

SECTION 2 - STEP 1

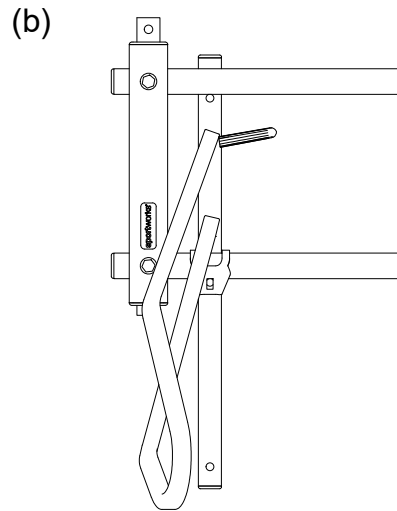
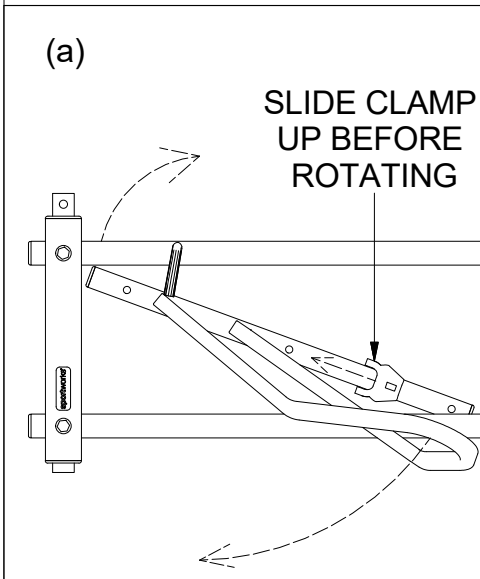

Install this first bicycle support in the low position about 2" to the right of the left hand upright. If you have the optional security cables for this rack, please refer to the assembly instructions that came with the security cables now.

Slide a clamp up the rectangular tube as shown in (a). Rotate to put the rectangular tube portion of the bike support behind the cross-members. Hook the clamp around the lower cross-member as shown in (b).

For more high versus low position bike mounts, refer to Step 4 of Section 5.

SECTION 2 - STEP 2

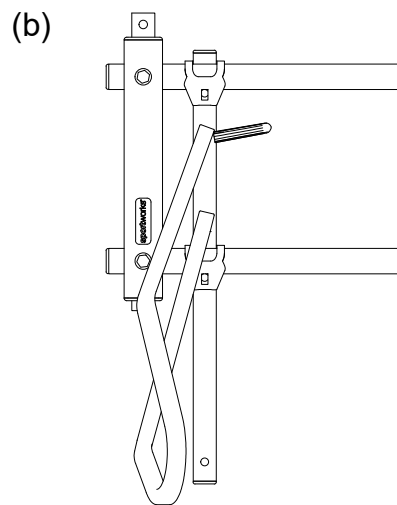
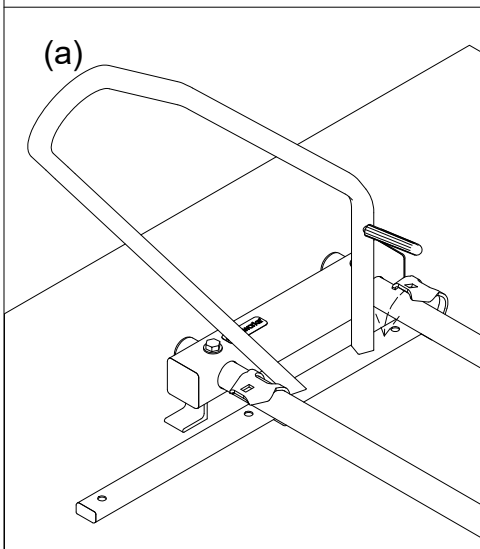

Position the second clamp by sliding down the rectangular tube and around the upper cross-member as shown in (a). Let clamp rest around the cross-member as shown in (b).

SECTION 2 - STEP 3

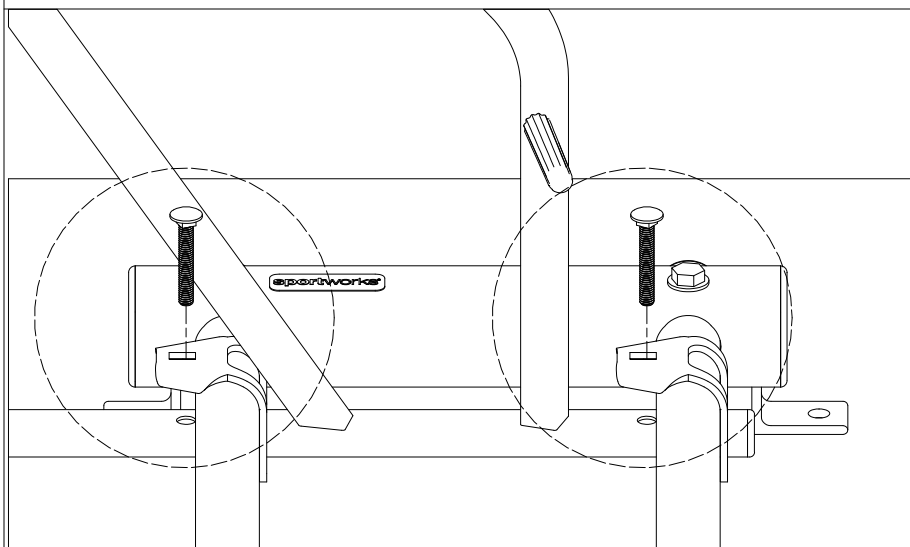

Place a carriage bolt through each of the square slotted holes in the front of the two clamps and into the corresponding holes in the front of the vertical tube of the bicycle support as shown.

SECTION 2 - STEP 4

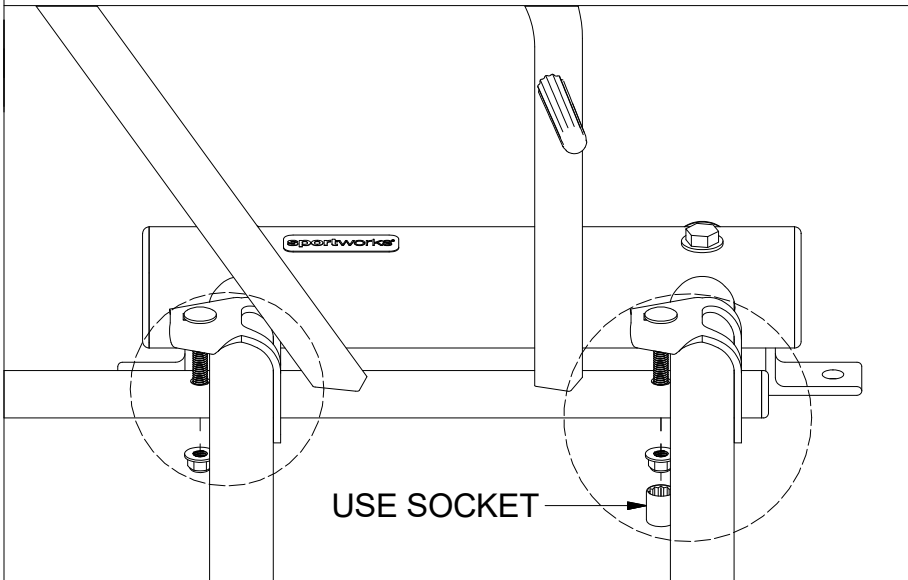

Using a 9/16" socket, place a locking flanged hex nut into the socket, then insert the nut through the corresponding hole in the back of the rectangular tube and thread the nut onto the carriage bolt. Repeat for the second carriage bolt. Thread the nuts until the locking portion of the nut is reached.

Hand tighten only.

SECTION 2 - STEP 5

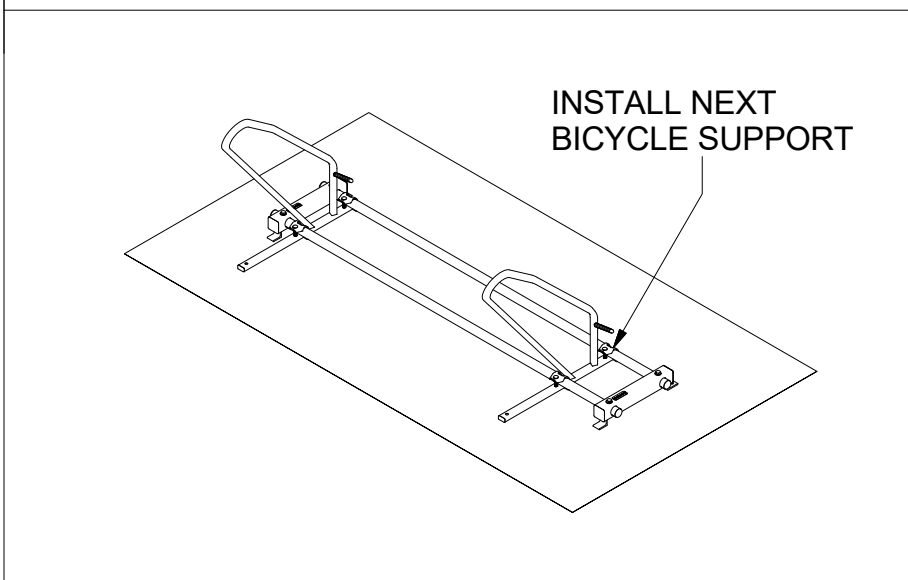

Now install another bicycle support, this time a few inches to the left of the right hand upright.

Like the first bicycle support, install this last odd numbered bicycle support in the lower position by following Steps 1 through 4 of Section 2.

SECTION 2 - STEP 6

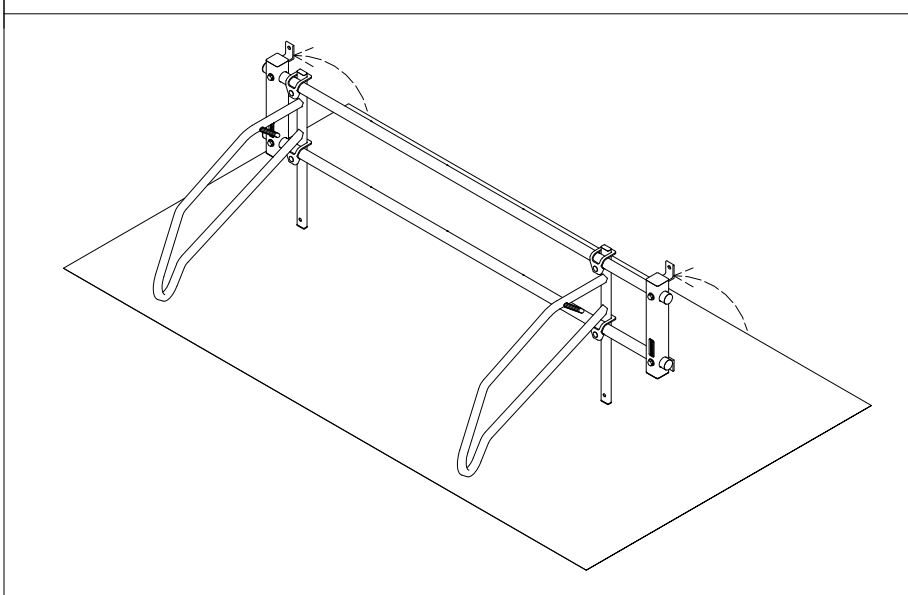

Now flip the assembly up so the uprights are oriented vertically and the assembly is resting on the bottom edges of the bike supports as shown. This will make installing the remaining bike supports easier.

SECTION 2 - STEP 7

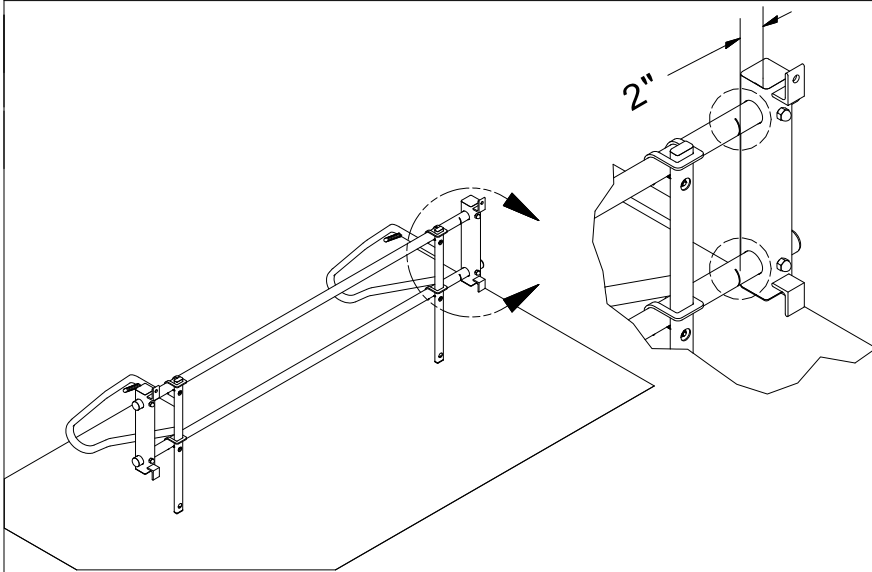

Mark the first bicycle support location on the back of both cross-members using a tape measure and a felt pen. Standing behind the cross-members, mark the first location 2" to the left of the inside edge of the right upright.

SECTION 2 - STEP 8

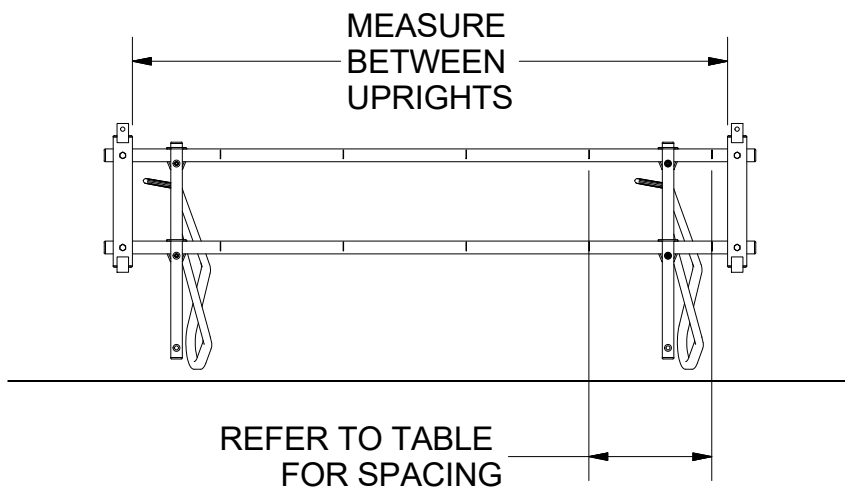

Mark the remaining bicycle support locations on the back of the cross-members by measuring from the first two 2" marks you made. Refer to the table below to determine the remaining bicycle support locations. Mark both cross-members for each bicycle support location.

For spacing other than 13" or 16" between bikes, refer to Step 3 of Section 5 now.

SECTION 2 - STEP 9

To determine the correct spacing between bicycle supports, measure the distance between the inside edges of the uprights with a tape measure (see diagram in Step 8 of Section 2). Match the distance between uprights to that shown in the table here to determine spacing.

CROSS-MEMBER PART NUMBER:	DISTANCE BETWEEN UPRIGHTS ("):	SPACING BETWEEN BICYCLE MOUNTS ("):	TOTAL # OF BIKE SUPPORTS:
300312(-0006)	45.5	16	3
300313(-0006)	77.5	16	5
300314(-0006)	109.5	16	7
300315(-0006)	49.5	13	4
300316(-0006)	75.5	13	6
300317(-0006)	114.5	13	9
300320(-0006)	71.5	18	4
300321(-0006)	125.5	18	7

Note: Cross-member length = distance between uprights plus 2".

SECTION 2 - STEP 10

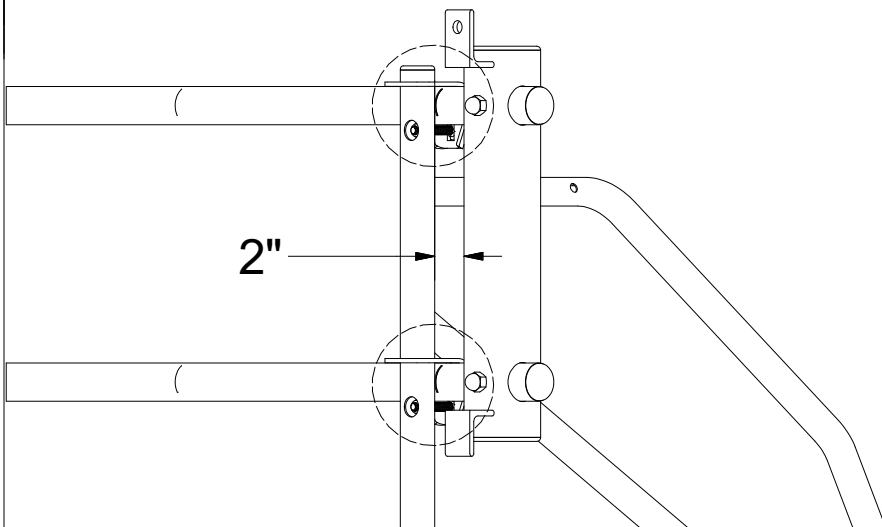

Align the left hand edge of the first bicycle support's rectangular tube with the first two marks you made in Step 7 of Section 2.

SECTION 2 - STEP 11

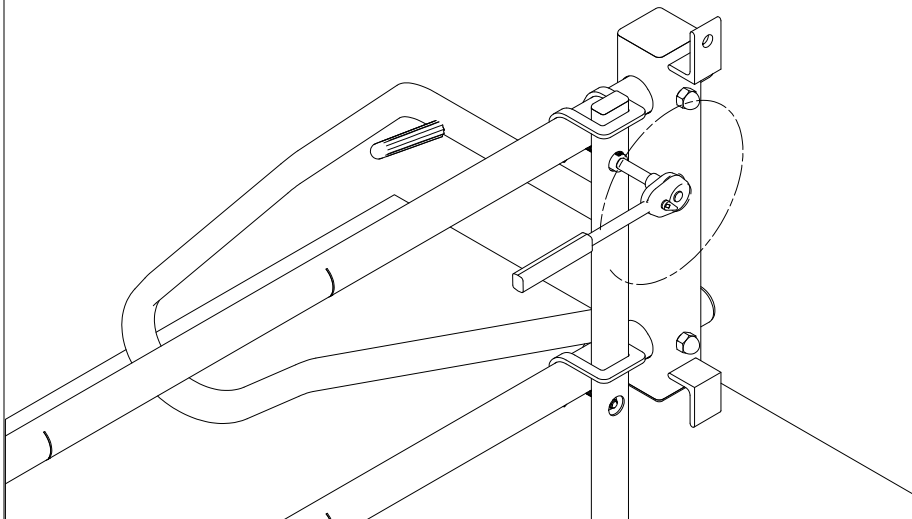

Using a 9/16" socket and ratchet, tighten the flanged hex nuts for both clamps on the installed bicycle supports.

SECTION 2 - STEP 12

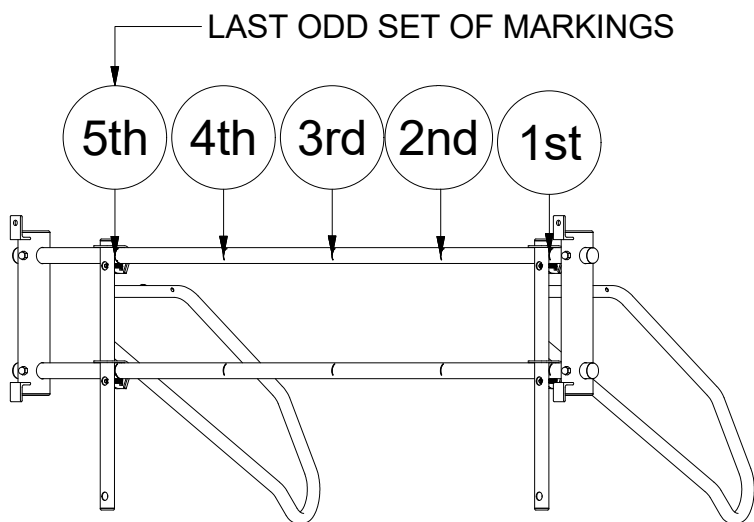

Align the left hand edge of the second bicycle supports rectangular tube with the last odd set of markings you made in Step 8 of Section 2.

For example, if you are assembling a 4 bike rack, the 3rd set of markings are the last odd.

Then tighten both flanged hex nuts following Step 11 of Section 2.

SECTION 2 - STEP 13

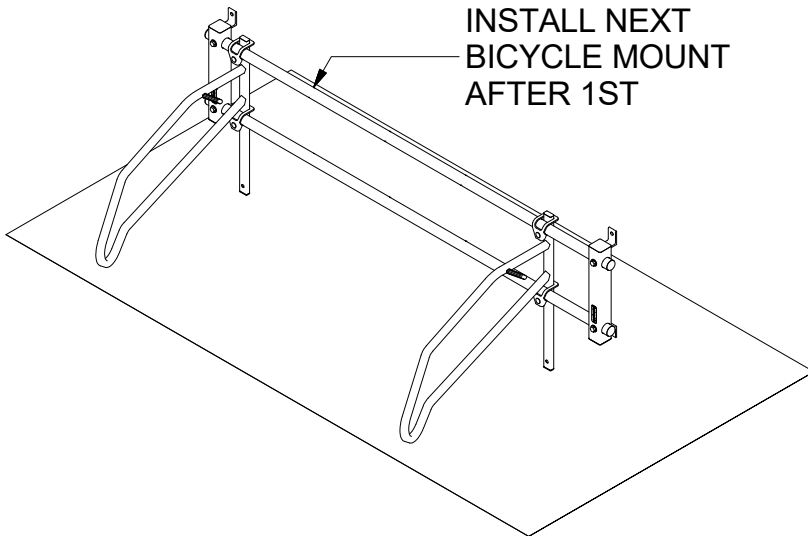

Starting back at the first bicycle support installed, install the next bicycle support (to the right of the first) in the upper position following Steps 14 through 16 of Section 2.

SECTION 2 - STEP 14

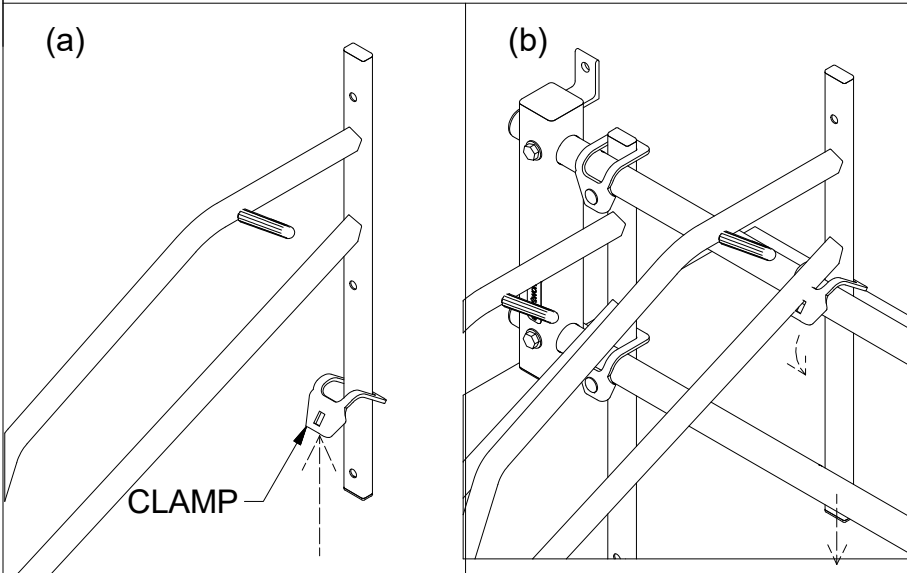

Slide a clamp up the rectangular tube as shown in (a), prior to installing this bicycle support in the upper position. Ensure the rectangular tube portion of the support is positioned behind the cross-members and hook the clamp over the top of the uppermost cross-member as shown in (b).

SECTION 2 - STEP 15

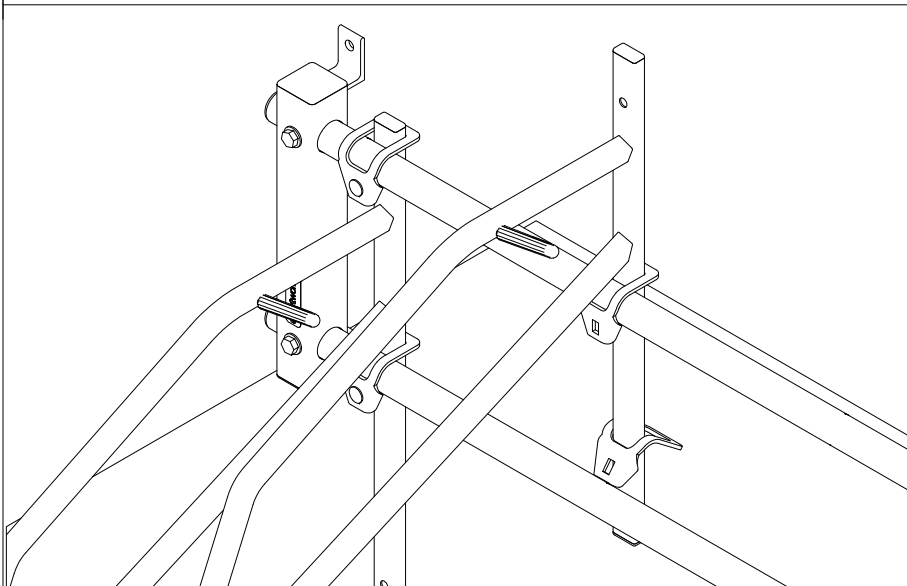

Position the second clamp by sliding up the rectangular tube. Push the lower portion of the rectangular tube back so the clamp can be hooked around the lower cross-member as shown. Then repeat Steps 3 and 4.

SECTION 2 - STEP 16

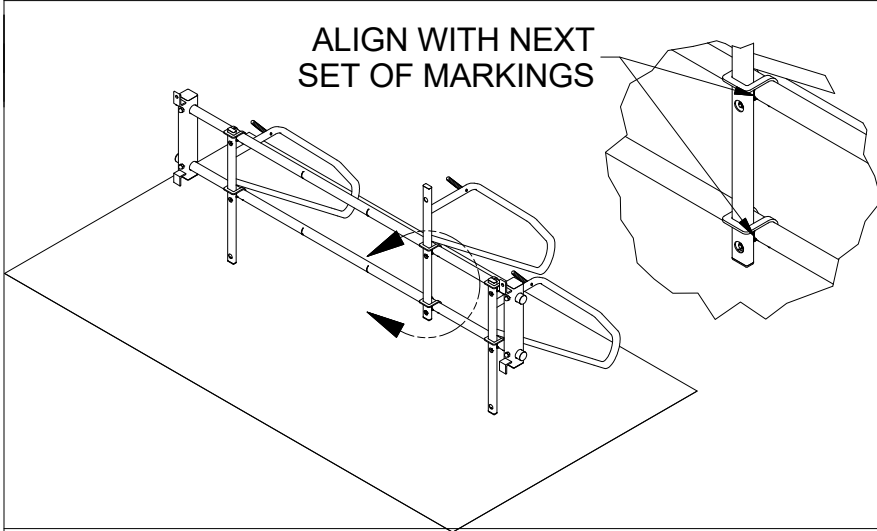

Align the left hand edge of the bicycle support's rectangular tube with the next set of markings you made in Step 8 of Section 2, then tighten both flanged hex nuts following Step 11 of Section 2.

SECTION 2 - STEP 17

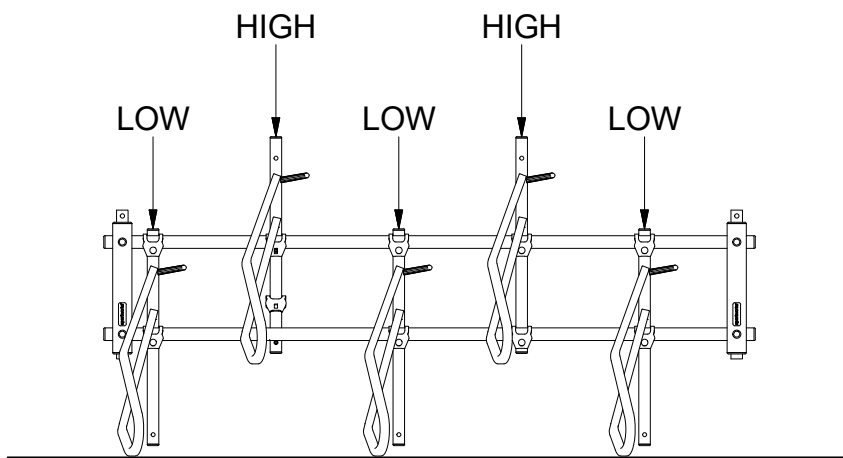

Continue installing the remaining bicycle supports ensuring each is alternating in height (low, high, low, high, etc.).

For installing bicycle supports in the lower position follow Steps 1 to 4 and 11 of Section 2.

For installing bicycle supports in the upper position follow Steps 14 through 16 and Step 11 of Section 2.

SECTION 2 - STEP 18

To increase the security of the rack, the shown security rings can be installed in two different ways to achieve varying levels of security (for security ring guidelines and removal, see Step 1 of Section 5). Select your desired level of security and install as shown:

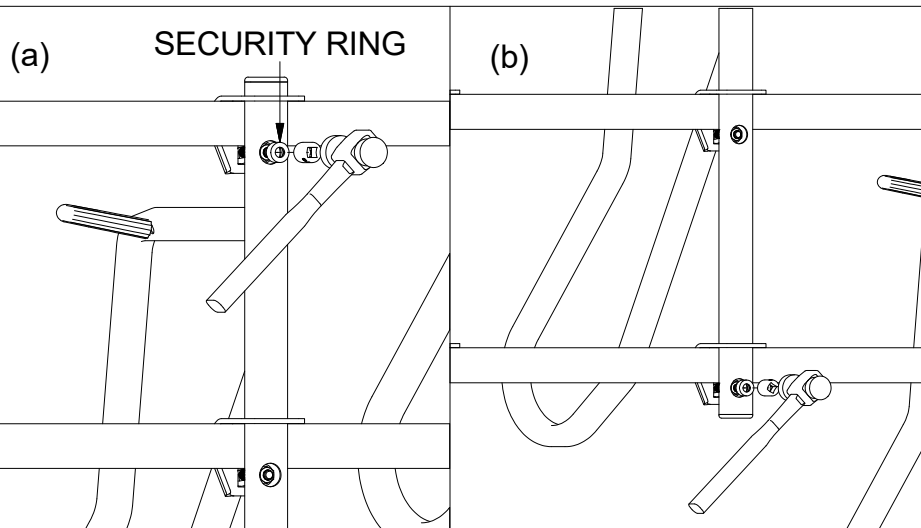

For **MEDIUM** security, use a 9/16" socket and a hammer to tap a security ring around the locking flanged hex nut of the upper clamp for each bicycle support in the lower position as shown in (a), and the lower clamp for each bicycle support in the upper position as shown in (b).

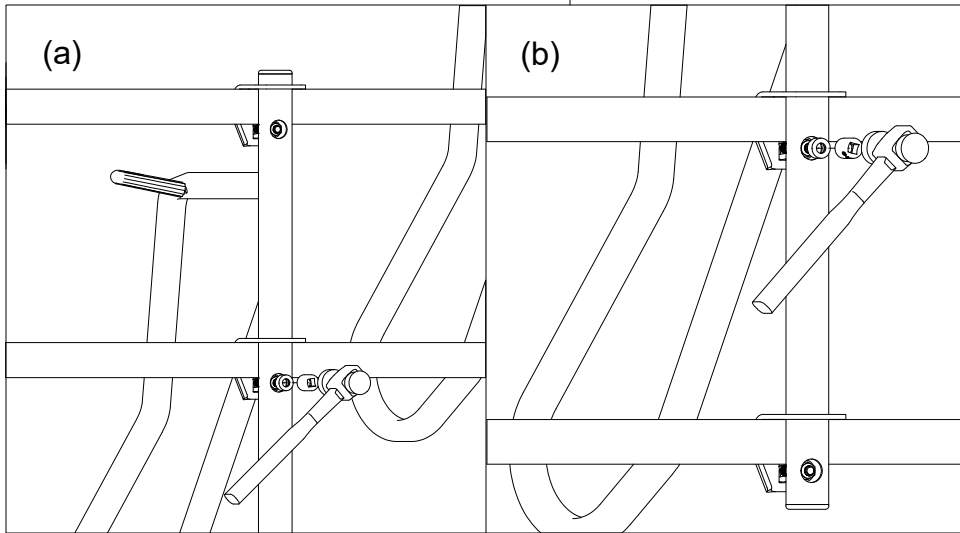

For **HIGH** security, use a 9/16" socket and a hammer to tap a security ring around the locking flanged hex nut of the lower clamp for each bicycle support in the lower position as shown in (a), and the upper clamp for each bicycle support in the upper position as shown in (b).

SECTION 2 - STEP 19

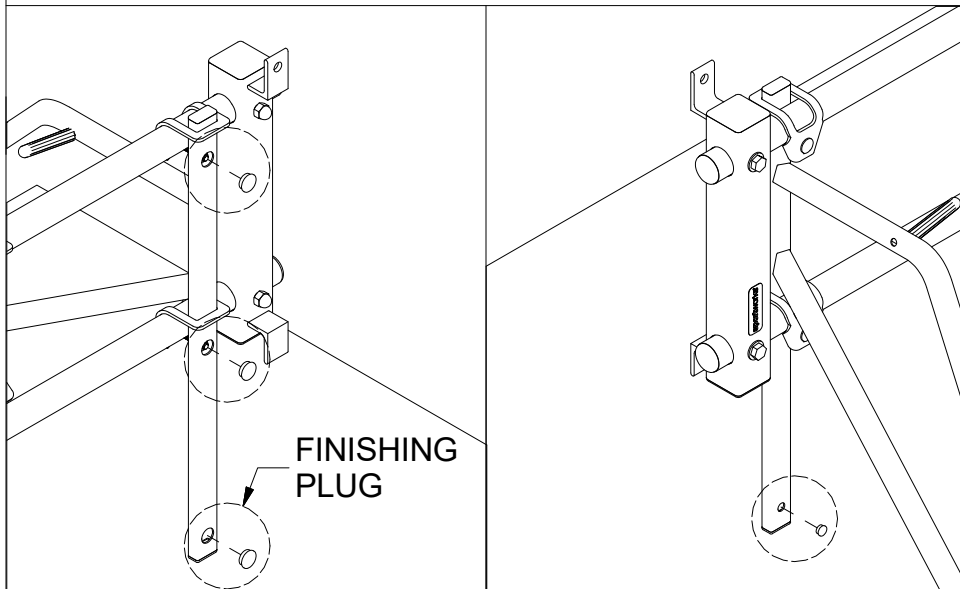

Install larger finishing plugs in all three holes in the back of each bicycle support as shown in (a).

Install the smaller finishing plug in each hole in the front of each bicycle support as shown in (b)

SECTION 3 - MOUNTING RACK TO THE WALL

SECTION 3 - STEP 1

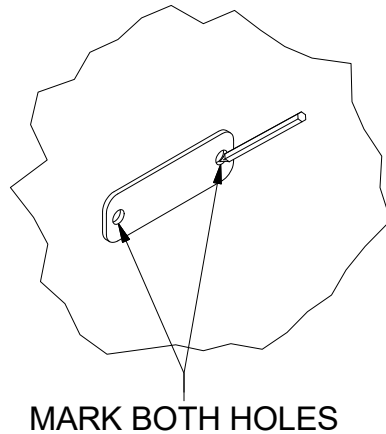
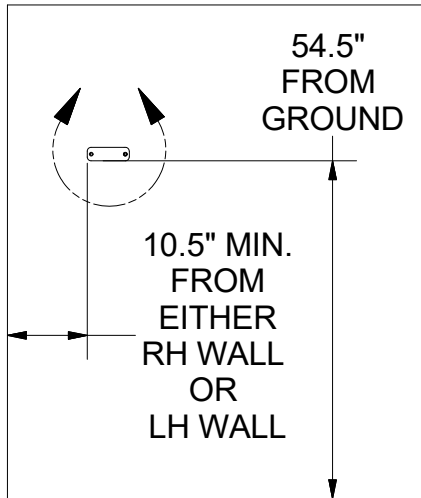

Determine the first wall mount bracket location by referring to the diagram to the left.

Once the ideal bracket location has been determined, use the front wall mount bracket (pictured) as a template. Level the bracket horizontally and mark the two hole locations on the wall.

SECTION 3 - STEP 2

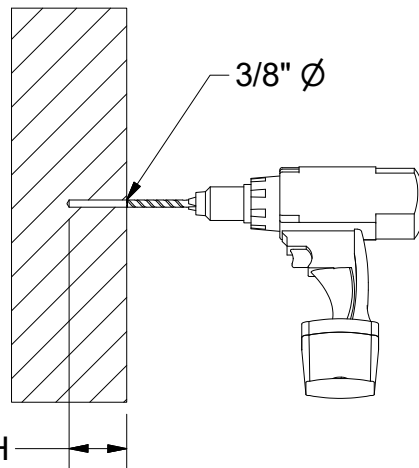
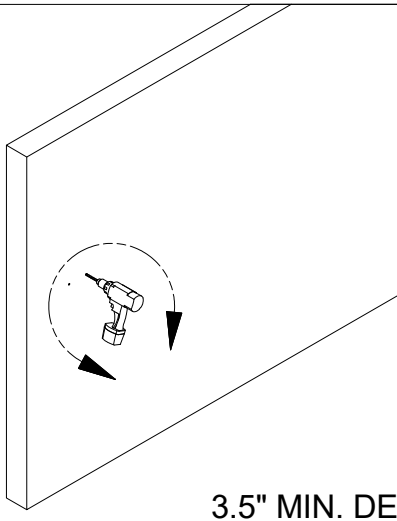

Using a hammer drill and a 3/8" carbide tipped hammer drill bit (following ANSI Standard B212.15) drill a hole on each of your installation marks.

The required minimum hole depth is 3.5" for Sportworks supplied 3/8" anchors. Or as specified by the anchor manufacturer.

Remember to clean the drilled holes with a wire brush, compressed air, or a vacuum (wear eye protection).

SECTION 3 - STEP 3

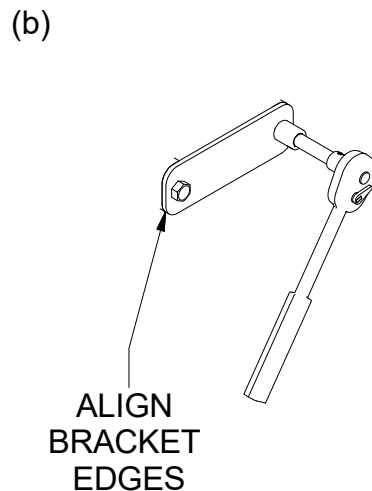
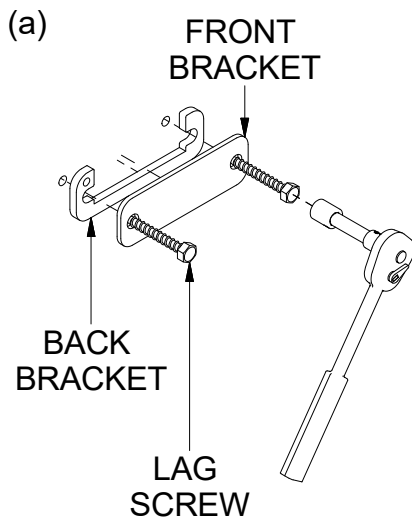

Place the front and back wall mount brackets against the wall and insert a lag screw through each of the bracket mounting holes as shown in (a).

Use a ratchet and a 9/16" socket to screw into place until the head of both screws just contacts the mounting bracket.

Align the edges of both front and back brackets as shown in (b), then tighten both lag screws to a torque of 40 ft-lbs.

SECTION 3 - STEP 4

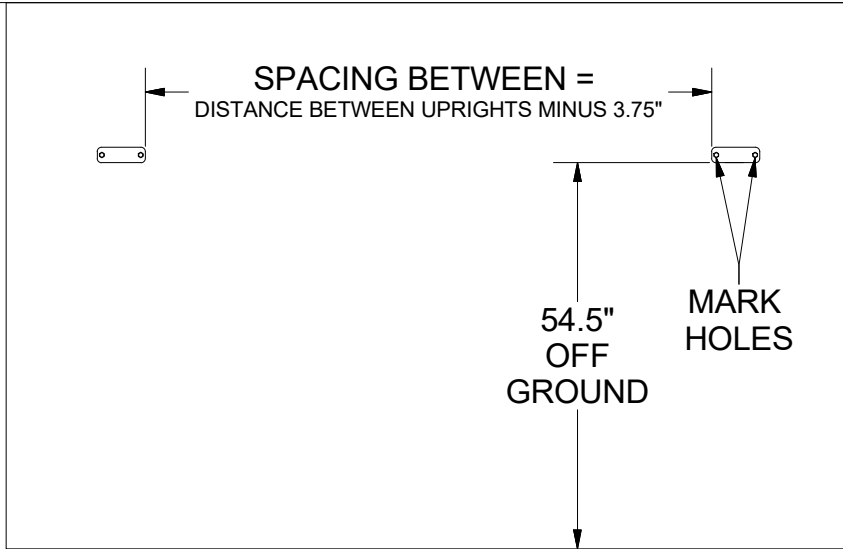

Determine the next wall mount bracket location by referring to the diagram to the left and the table in Step 8 of Section 2.

Once this brackets location has been determined, use the front wall mount bracket as a template and mark the two hole locations on the wall.

Repeat Steps 2 and 3 of Section 3 to finish anchoring this bracket to the wall.

SECTION 3 - STEP 5

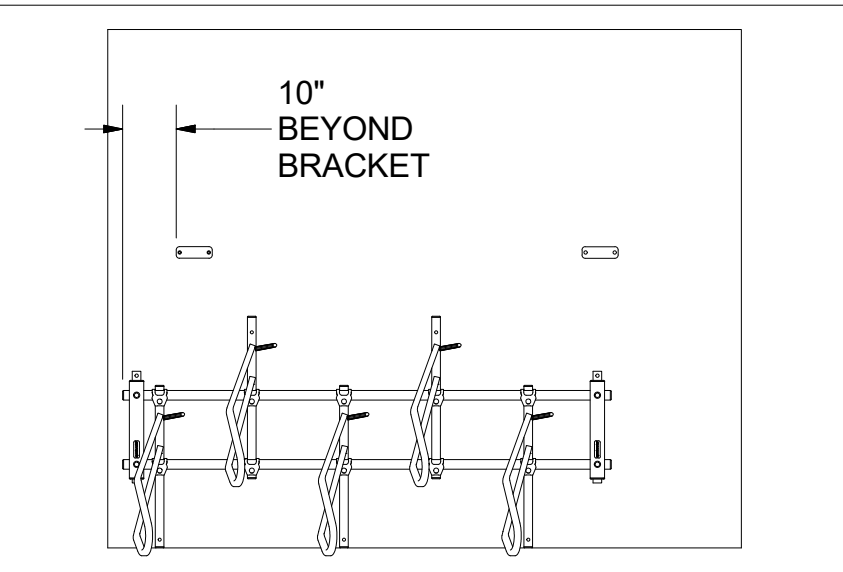

Position the assembled rack as close to the wall as possible for ease of mounting.

Also, if possible position one end of the rack approximately 10" either to the left or right of one of the wall mount brackets.

SECTION 3 - STEP 6

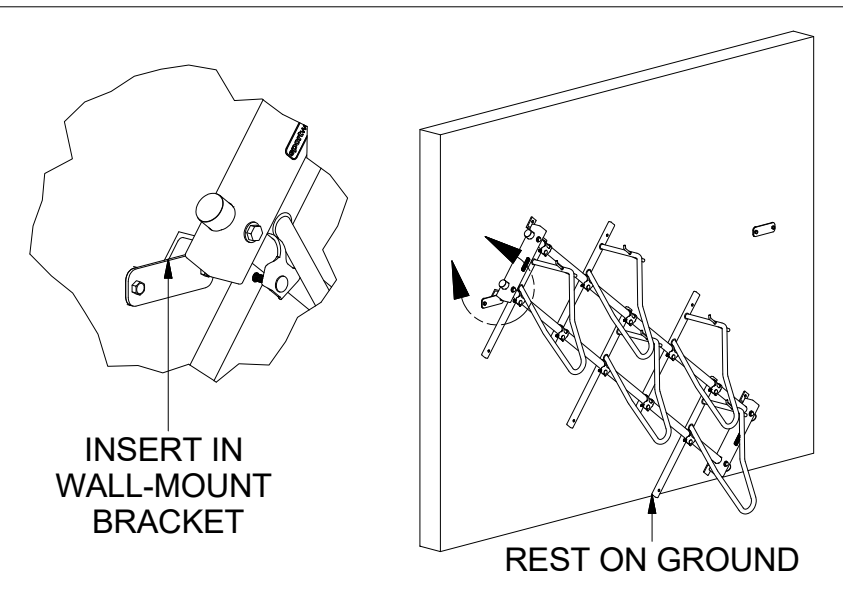

Lift up the side of the rack that is 10" beyond the wall mount bracket so the lower L-bracket of the upright can be inserted into the wall mount bracket as shown.

Let the other side of the rack rest on the ground as shown.

NOTE: 3 or 4 bike capacity racks are too short to rest on ground and must be installed into both wall mount brackets simultaneously.

SECTION 3 - STEP 7

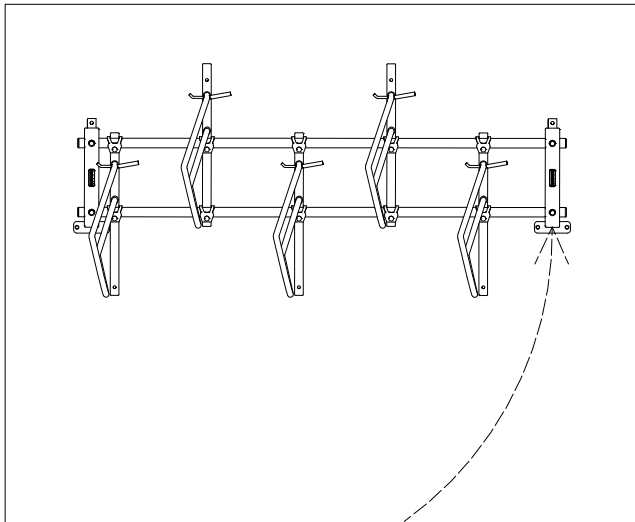

Lift up the opposite side of the rack, resting on the ground, and insert the lower L-bracket of the upright into the remaining wall mount bracket as shown.

The rack will hang by itself slightly away from the wall.

SECTION 3 - STEP 8

MOVE TO CENTER

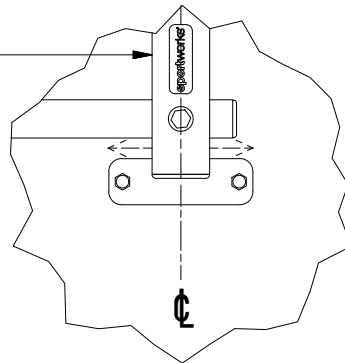
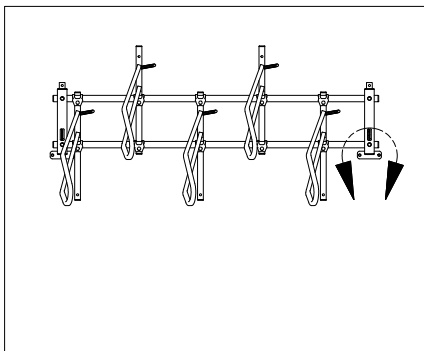

Center the upright laterally within the wall mount bracket as shown. To easier move the rack laterally, push the top of the rack towards the wall while pushing either to the left or to the right as required.

SECTION 3 - STEP 9

MARK LOCATION

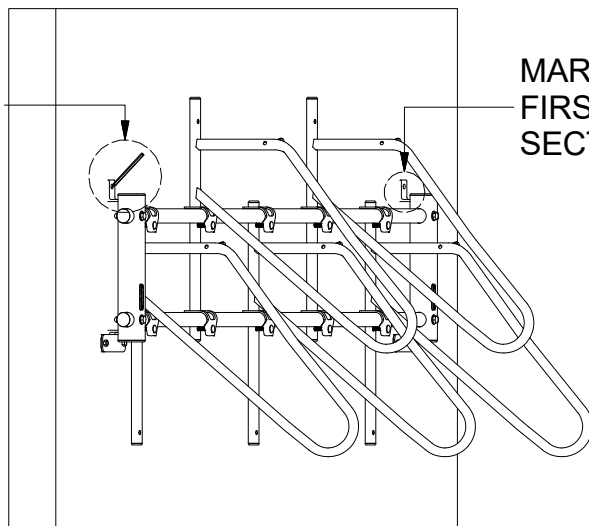

MARK IF FIRST SECTION

Once the upright has been centered with the wall mount bracket, push the rack up against the wall and mark the mounting hole location through the upper L-bracket of the upright as shown.

If this is the first section being installed, repeat for the other upright.

SECTION 3 - STEP 10

MARKED HOLE LOCATION

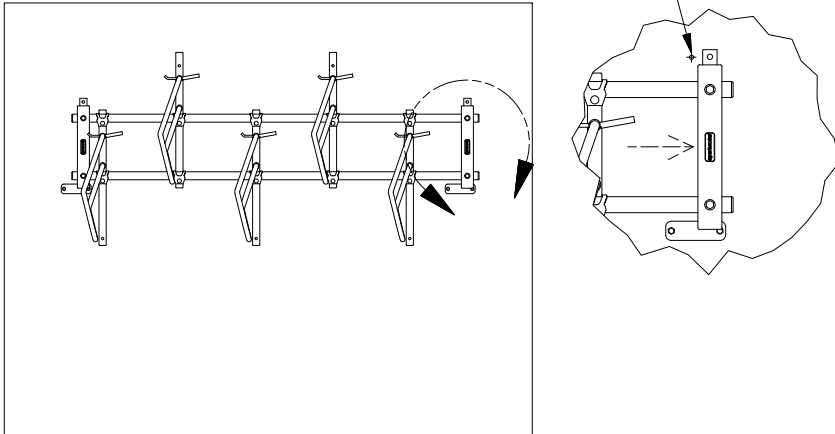

Slide the rack laterally to the left or right in order to get access to each marked hole location with a drill. Follow Step 2 of Section 3 to drill a 3/8" hole for each marked location.

SECTION 3 - STEP 11

ALIGN WITH DRILLED HOLES

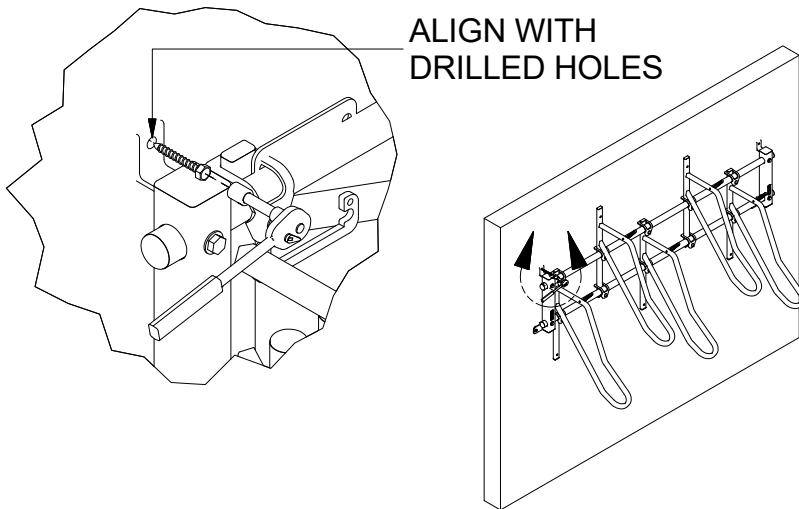

Slide the rack back so that the holes in the L-brackets in the uprights align with the drilled holes in the wall as shown. Insert a lag screw through one of the upright L-brackets and fasten it to the wall using a 9/16" wrench.

Repeat for the other upright.

SECTION 4 - ADDING SECTIONS

SECTION 4 - STEP 1

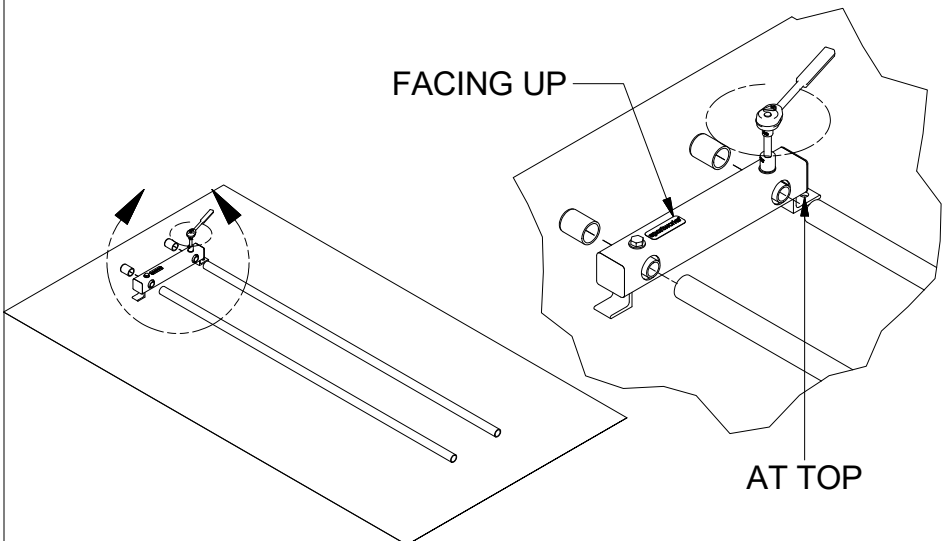

Place the next sections upright on the ground, face up as shown. Only one upright is required this time. Install both cross-members from the right hand side of the upright as shown. Then install the end caps from the left and tighten both joints.

SECTION 4 - STEP 2

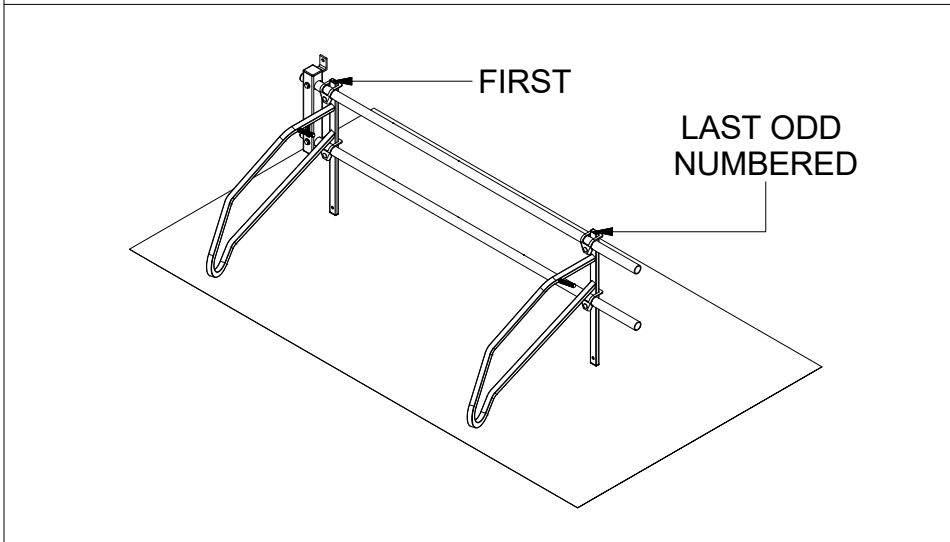

Install the first and last odd bicycle supports on the cross-members following Steps 1 through 5 of Section 2.

Flip the assembly up following Step 6 of Section 2.

Mark all the bicycle mount positions on the back of the cross-members following Steps 7 through 9 of Section 2.

SECTION 4 - STEP 3

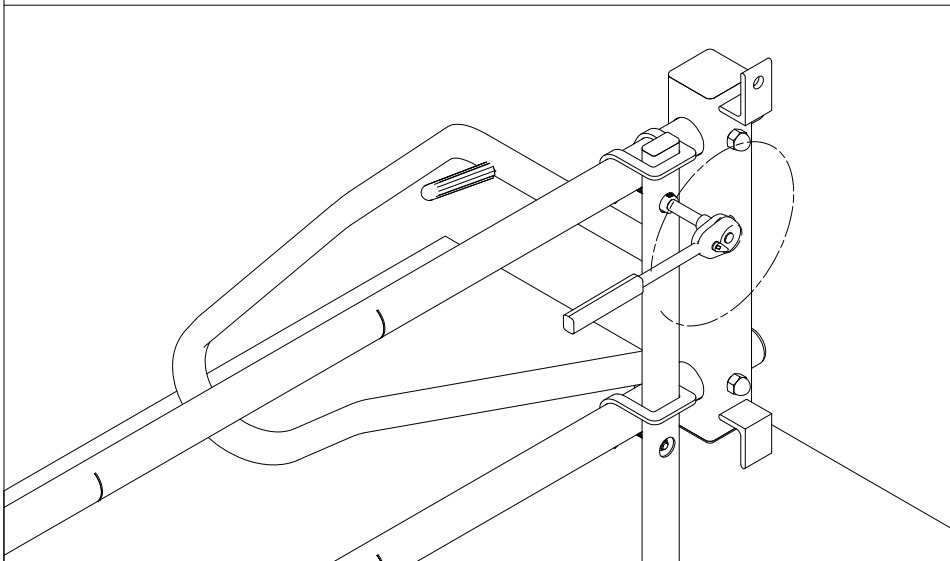

Tighten the first bicycle supports flanged hex nuts by following Step 11 of Section 2.

SECTION 4 - STEP 4

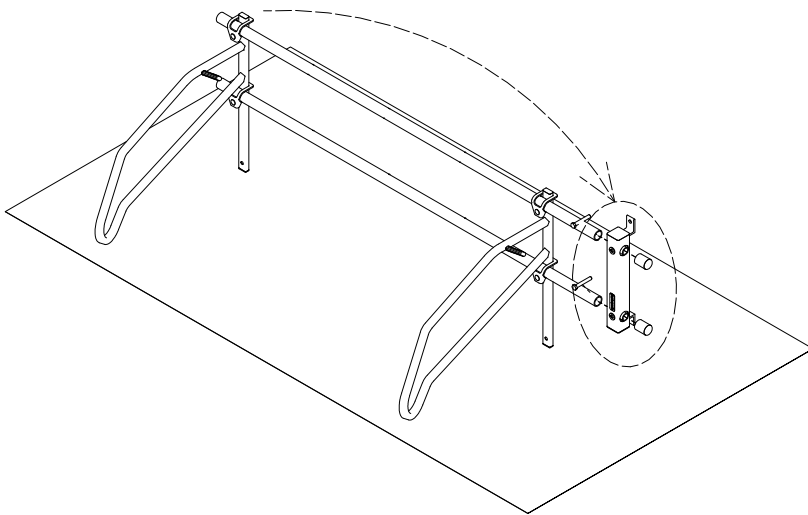

Remove the upright and end caps and install on the right hand side of the cross-members as shown.

SECTION 4 - STEP 5

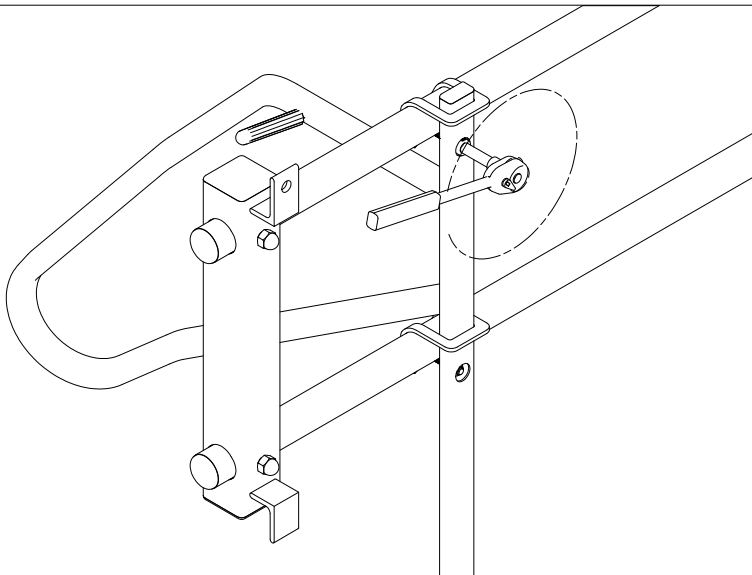

Tighten the last odd bicycle supports flanged hex nuts by following Step 11 of Section 2.

SECTION 4 - STEP 6

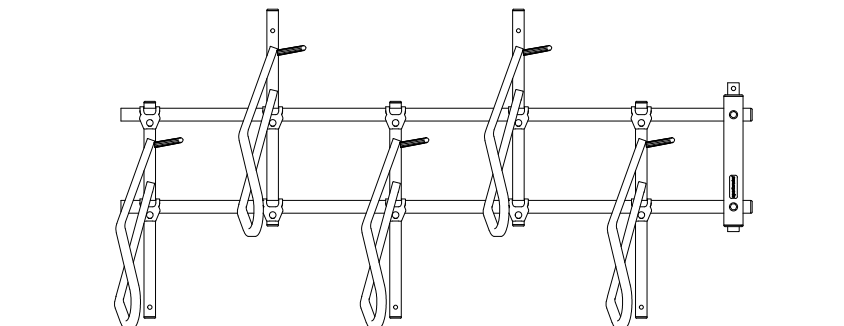

Install the remaining bicycle supports for this rack by following Steps 17 through 19 of Section 2.

SECTION 4 - STEP 7

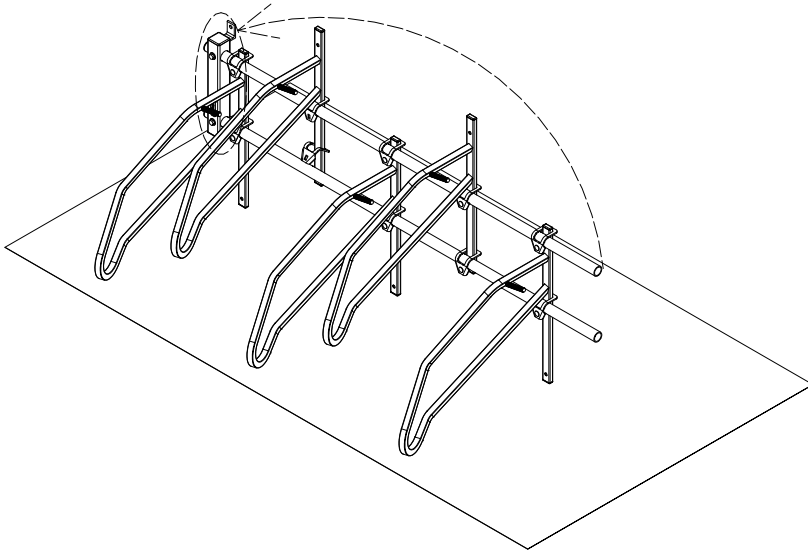

If this rack is to be joined to the right of the last rack installed on the wall, proceed to Step 8 of Section 4.

If this rack is to be joined to the left of the last rack installed on the wall, remove the upright and end caps and install them on the left end of the cross-members.

SECTION 4 - STEP 8

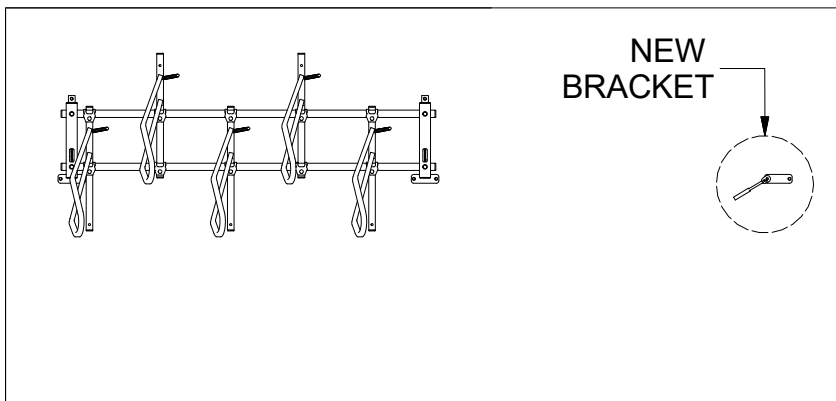

Determine which side this next section will be joined to the last section installed.

Install the next wall mount bracket on this side by following Step 4 of Section 3.

SECTION 4 - STEP 9

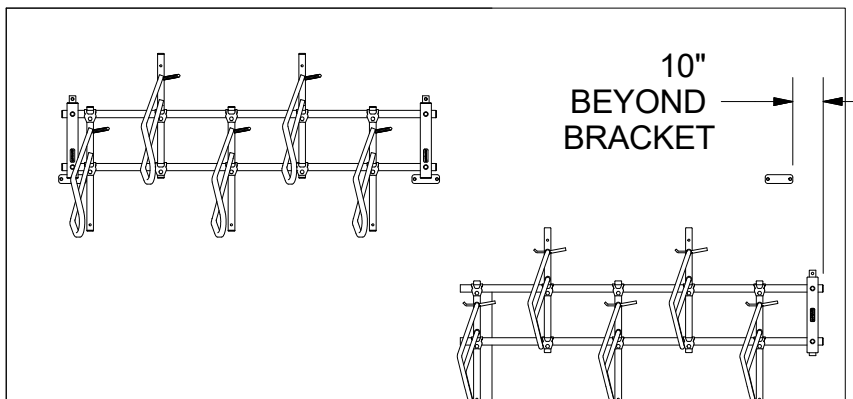

Position the assembled rack as close to the wall as possible for ease of mounting. Also, if possible position the end of the rack with the upright either 10" to the left or right of the free wall mount bracket.

If the free wall mount bracket is to the right of the last rack installed, position the end with the upright 10" to the right of the wall mount bracket (as shown), or vice-versa.

SECTION 4 - STEP 10

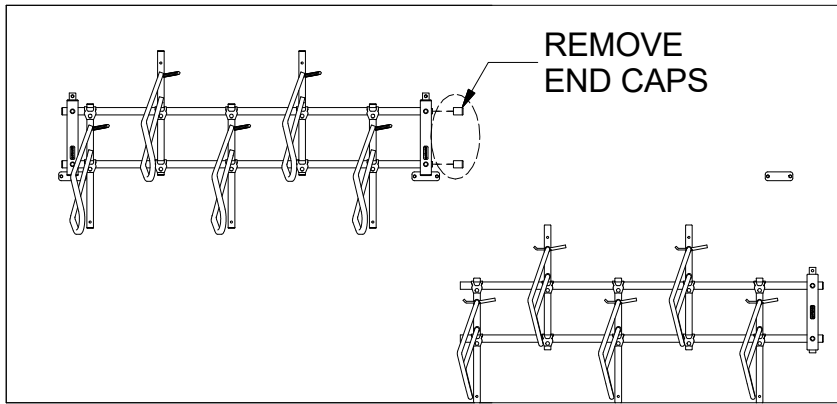

Before installing this next section to the wall, determine which side this section will be joined to the last.

Loosen both joints and remove both end caps of this sides upright.

SECTION 4 - STEP 11

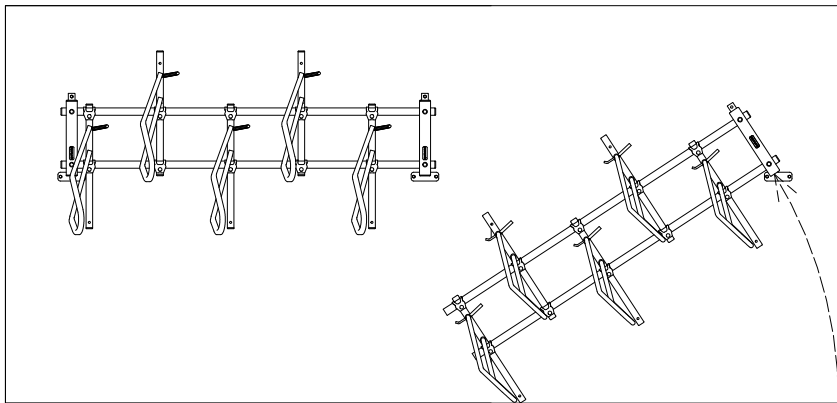

Lift up the side of the rack that is 10" beyond the free wall mount bracket by following Step 6 of Section 3.

NOTE: 3 or 4 bike capacity racks are too short to rest on ground and must be installed into both wall mount brackets simultaneously.

SECTION 4 - STEP 12

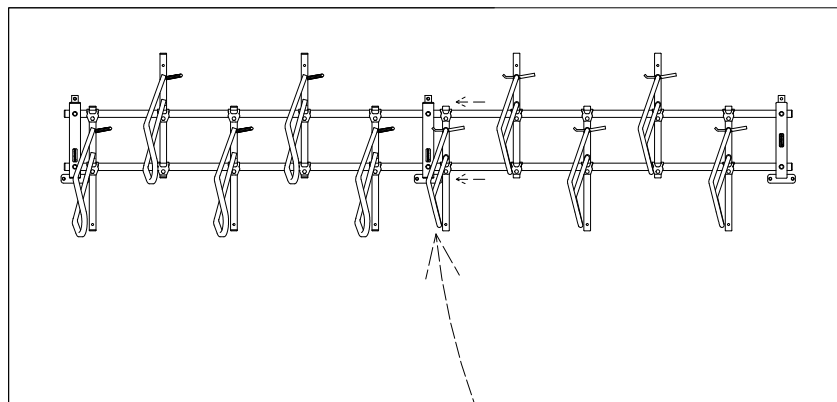

Lift up the other end of the rack and insert the cross-members into the upright. Ensure the cross-members are as far into the upright as they can go. Tighten both joints of this upright again.

SECTION 4 - STEP 13

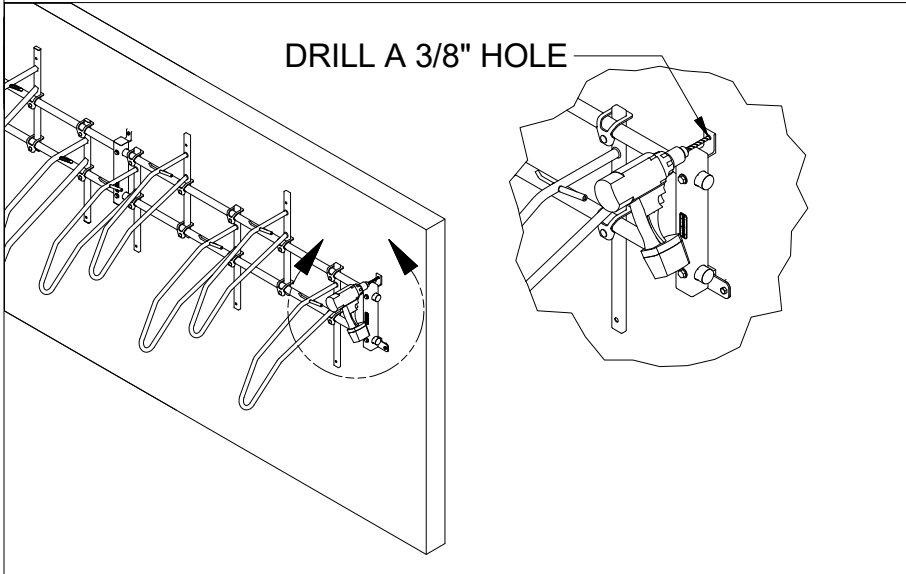

Push this new upright up against the wall and use the L-bracket as a guide to drill a 3/8" hole in the wall as shown.

Alternatively, if desired, the hole location can be marked and this new section removed from the wall for drilling.

SECTION 4 - STEP 14

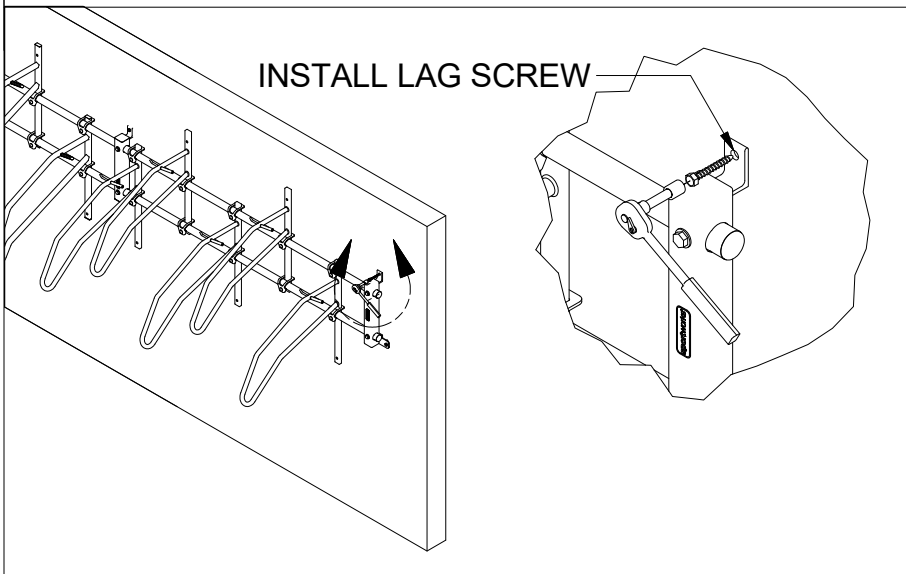

Bolt this upright to the wall by inserting a lag screw through the L-bracket and fastening it to the wall using a 9/16" wrench as shown.

SECTION 4 - STEP 15

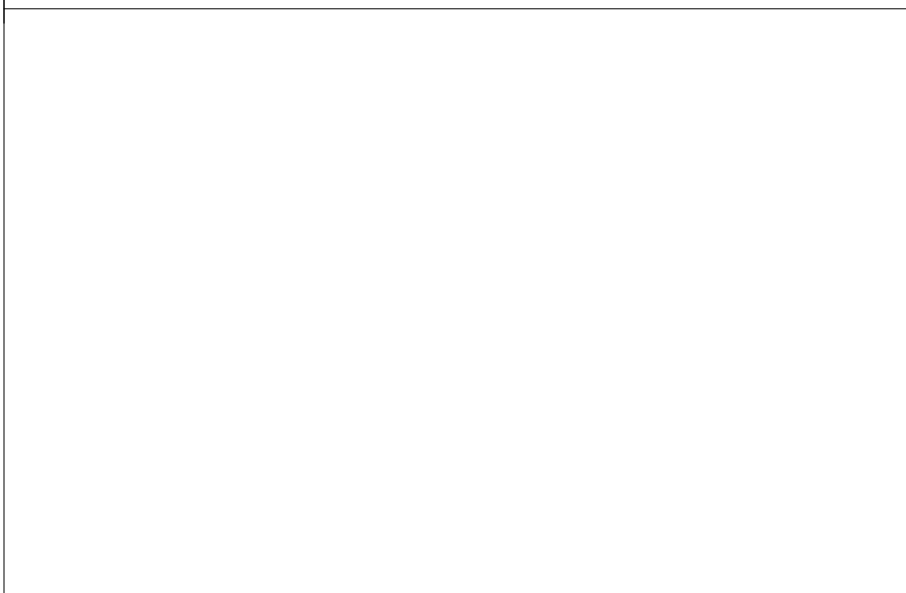

Repeat all steps of Section 4 for any remaining additional sections.

SECTION 5 - CUSTOMIZING RACK CONFIGURATION

SECTION 5 - STEP 1 - Security Ring: Guidelines and Removal

MEDIUM LEVEL: Intended for installations in secure areas where access is controlled by a combination lock or key card entry point/s. This level of security is also intended for situations where the rack may need to be relocated and/or reconfigured. An easy method of removing the security ring is shown below.

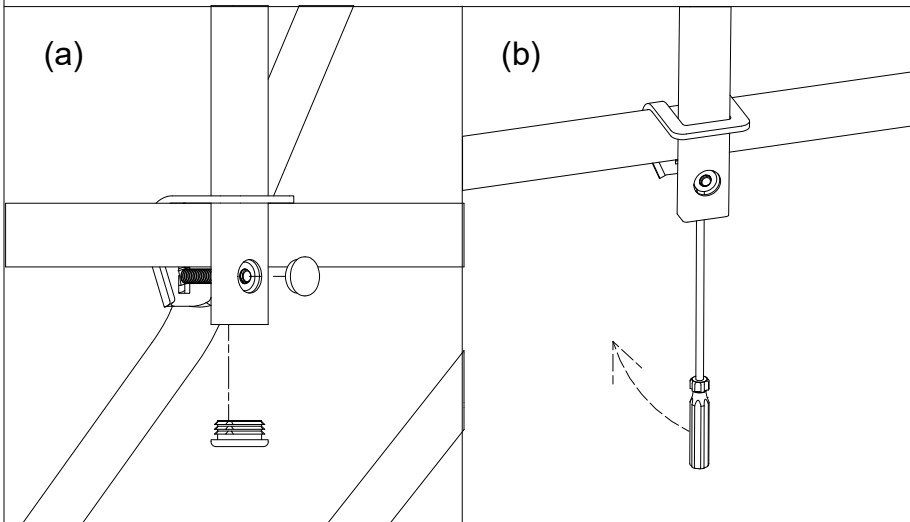

Start by removing the rectangular endcap in the end of the bike mount closest to the security ring and the round endcap hiding the security ring, as shown in (a).

Insert a screw driver between the security ring and surface of the flanged hex nut as shown in (b), then lever it off.

HIGH LEVEL: Intended for installations in less secure areas where access is not controlled. This level of security is also intended for situations where it is very unlikely the rack will need to be relocated and/or reconfigured. Although no easy method of removing the security ring is available, a method is shown below.

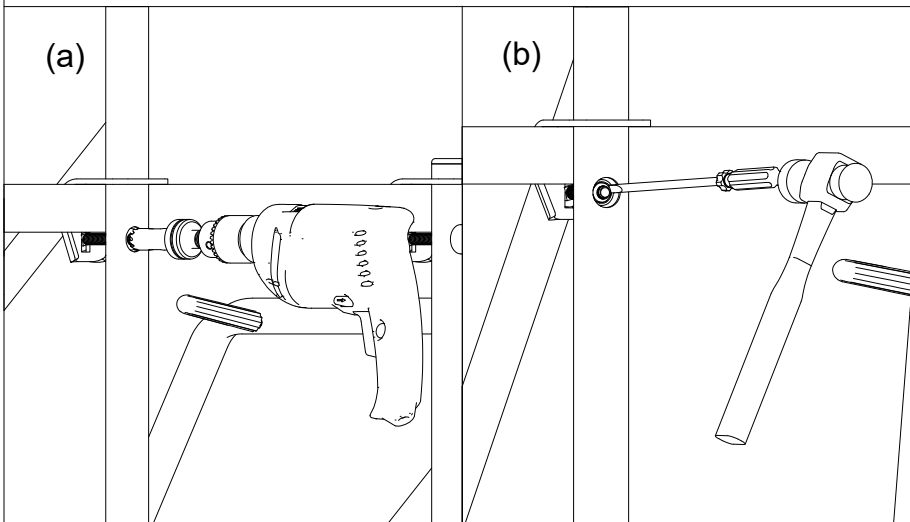

Start by removing the round endcap hiding the security ring.

Use a 3/4" hole saw (with the pilot drill removed) and a drill to drill the flat face away from the security ring as shown in (a).

Insert a screw driver between the security ring and the flat of the flanged hex nut, hit the screw driver with a hammer until the remaining portion of the security ring breaks, then remove it.

SECTION 5 - STEP 2 - Shortening Cross-Members

All cross-members are galvanized 1.25" Schedule 40 pipe, and can be easily shortened to a desired length. It is recommended that cross-members are shortened in 13" or 16" increments to preserve bicycle spacing. Typically, for every 13" or 16" length that is removed, one bicycle mount on each side is also removed. It is best to shorten cross-members prior to assembly, however, if the rack has already been assembled, disassemble the rack to get access to the cross-members by following Step 5 of Section 5.

SECTION 5 - STEP 3 - Reducing or Increasing Bike-to-Bike Spacing

Horizontal spacing between bicycles can be altered to either reduce or increase bike parking capacity. This is easily achieved by loosening the locking flanged hex nuts of the bike support clamps and sliding the bike supports closer together or further apart. 16” spacing is the best compromise between usability and density. Spacing as low as 13” has worked for some users.

SECTION 5 - STEP 4 - Altering High versus Low Position Bike Mounts

The standard rack installation renders more bike supports in the low position, this is because most people prefer not to lift their bicycles higher than they need to (see Page 7, Step 17). In some situations it may be desirable to have more bike supports in the high position (e.g. if most people have extremely long wheelbase bikes). To configure the rack to have more high position bike supports follow the instructions below.

- | | |
|---|---|
| 1 | Instead of installing the first and last odd bike supports in the low position, install them in the high position, following Steps 14 through 16, then Steps 10 through 12 of Section 2. |
| 2 | Install the next bike support in the low position, follow Steps 1 through 4 and 11 of Section 2. |
| 3 | Continue to follow Steps 17 through 19 of Section 2 ensuring bicycle supports are alternating in height (high, low, high, low, etc.). This installation sequence will render more bike supports in the high position. |

SECTION 5 - STEP 5 - Cross-Member Replacement

- | | |
|----|---|
| 1 | Remove the section of rack from the wall which requires cross-member replacement. It may be necessary to remove one rack section at a time. If so, start with the outer most section and work inwards until the rack requiring cross-member replacement can be removed. |
| 2 | Start by removing the lag screw (shown in Step 14 of Section 4), from the L-bracket of the second most outer upright. |
| 3 | Loosen both joints of this upright then slide the rack laterally away from the upright to free one end of the rack. Rotate this free end to the ground. |
| 4 | Unhook the opposite end of the rack from the wall mount bracket and rotate to the ground. |
| 5 | Repeat Steps 1 to 3 of Section 5 for any remaining sections requiring removal. |
| 6 | Remove the large finishing plugs on the back of the bicycle supports. Then remove the security rings if required by following Step 1 of Section 5. |
| 7 | Unscrew all of the clamp locking flanged hex nuts and remove bicycle supports. |
| 8 | Lay rack over on ground as shown in Step 3 of Section 1. |
| 9 | Loosen all upright joints and replace existing cross-members. Refer to Steps 1 to 3 of Section 1 for upright joint locations and tool recommendations. |
| 10 | Reassemble rack by following all assembly steps detailed in Sections 1 through 3. Also, for re-assembling additional sections, follow all assembly steps detailed in Section 4. |