

DL2 & DL2 NP Operation and Maintenance

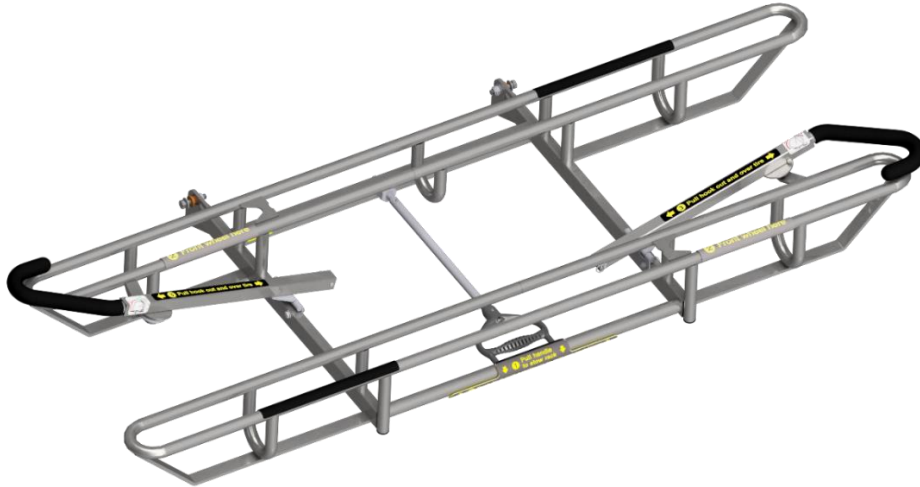

SCOPE OF THIS DOCUMENT 2

INSTALLATION & OVERVIEW 3

 Load Height 3

 Approach Angle 3

 Protrusion 3

 Bicycle/Wiper Clearance..... 4

 Front Mask Clearance..... 4

 Footprint..... 4

 Mounting the DL2 5

 General Torque Specs..... 6

OPERATION OF THE BIKE RACK 7

 Steps for Loading Bikes 7

 Steps for Unloading Bikes..... 8

 Compatible Bike Dimensions and Weight..... 9

BUS WASHING 10

VISUAL INSPECTION..... 11

 Visual Inspection Checklist 12

MAINTENANCE 13

 30 Day General Maintenance Inspection & Service..... 14

APPENDIX A – Latch Interface Inspection 16

 Travel Stop Washer Guide..... 17

DOCUMENT REVISION HISTORY 18

SCOPE OF THIS DOCUMENT

This Document applies to all DL2 racks. The DL2 product line is a 2-position bike rack with stainless steel support arms and either steel or stainless-steel frame and wheel trays. There are four main versions of the DL2 that differ in terms of material and frame geometry. The DL2 is available in either steel with a powder-coated finish, or stainless steel with an anti-glare finish. The NP version (Narrow Profile) has a narrower frame and narrow-styled wheel trays. The NP version is also available in steel with powder-coated finish, or stainless steel with an anti-glare finish. **All NP racks require a pivot plate compatible with the narrow frame.**

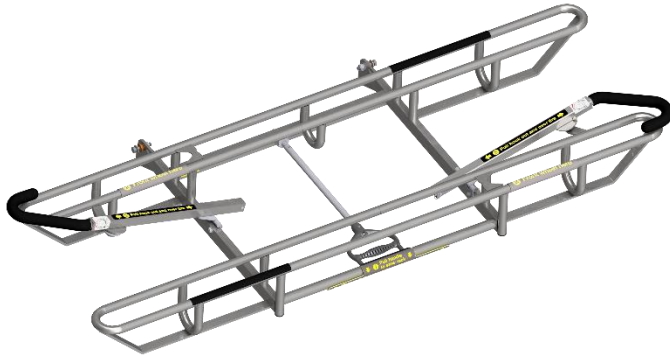

DL2 (standard frame and trays)

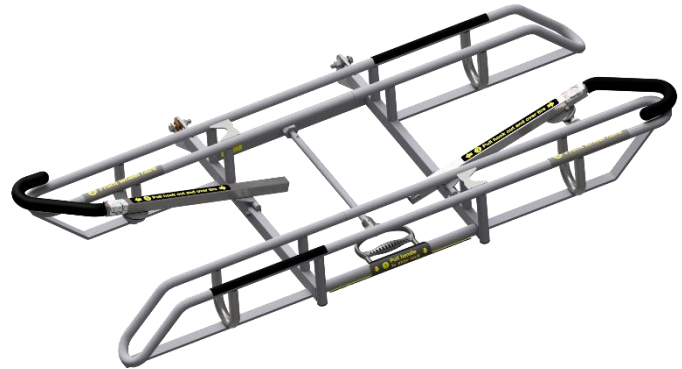

DL2 NP (narrow frame and trays)

- | | |
|--------------------------|----------------------------------|
| 100536-XXX or 100512-XXX | denotes a stainless steel DL2 |
| 100352-XXX | denotes a steel DL2 |
| 100540-XXX or 100460-XXX | denotes a stainless steel DL2 NP |
| 100434-XXX | denotes a steel DL2 NP |

INSTALLATION & OVERVIEW

The installation is crucial to the safety and performance of the Sportworks Bike-Rack-for-Buses system. There are several factors that need to be addressed when mounting the rack. These factors include the:

- Load Height
- Approach Angle
- Protrusion
- Bicycle/wiper Clearance
- Front Mask Clearance
- Footprint/Headlight Clearance

Carefully read and understand the following information regarding the positioning of the rack on the bus before beginning the installation process.

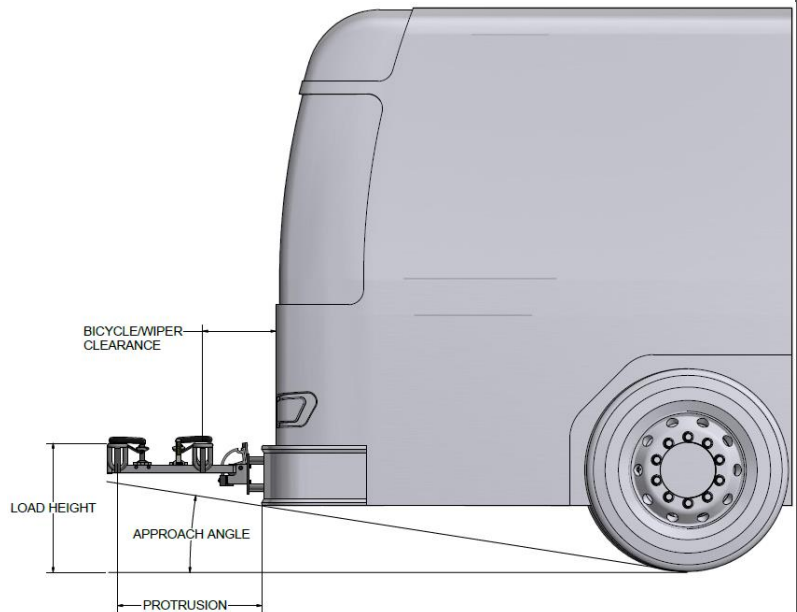

Load Height

The load height is the vertical distance a bicycle must be lifted for placement in a deployed bike rack. If the rack is mounted too high, some riders may have difficulty loading the rack.

Approach Angle

The approach angle is the angle created by a line from where the front tire contacts the pavement to the first obstruction ahead of the front tire. This obstruction would first touch the pavement when transitioning from flat to a very steep hill. APTA standards require a minimum approach angle of 8°, although some agencies in hilly areas may require 9°. The bike rack will limit the approach angle if it is installed on the bumper in a low enough position. The bike rack installer should be aware of this possibility. Investigate approach angle requirements in your area before mounting the rack.

Protrusion

Protrusion measures the distance from the front of the bumper to the front edge of the bike rack in the deployed position. Once the bike rack is mounted to the coach, the protrusion distance is fixed. Protrusion is a measurement that needs attention for three important reasons.

1. Many state DOTs (Departments of Transportation) have set limits for bike rack protrusion (e.g. California, one of the most restrictive DOTs, has set a protrusion limit of 40 inches measured from the front mask of the coach).
2. The further a rack protrudes, the more likely it will affect a coach's approach angle and turning radius. It will also influence the bicycle/wiper clearance, which could cause interference with windshield wipers or a coach driver's visual field.

Bicycle/Wiper Clearance

Bicycle/Wiper clearance is important to make sure that when a bicycle is loaded in the position closest to the bus, the handlebars do not come close enough to the wipers to interfere or be caught by them. Sportworks typically recommends ensuring at least 16 inches clearance between the center of the nearest tray and the wiper arms, although some vehicles may have unique requirements.

Front Mask Clearance

Front mask clearance is the clearance between the stowed rack and the wiper mechanism or front-most part of the bus mask. Sportworks recommends a minimum of 2 inches clearance, although some vehicles may have unique requirements.

Footprint

The footprint is the outline of a bike rack against the front of the bus when the rack is in the stowed position.

Avoid obstructing headlights, hi-beam headlights and turn signal indicators. To change the position of the rack, remove the bike rack from the pivot plate. Remove the pivot plate from the C-Brackets or other bracket pieces and position the pivot plate up or down as required. Remount the pivot plate to the bracket pieces and the rack to the pivot plate.

Some bracket assemblies may not have multiple height adjustment holes. If this is the case, the bracket assembly is designed for an optimum position in terms of minimal headlight interference and proper loading height. Height adjustment is not required.

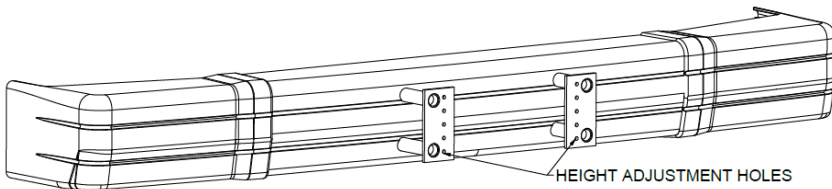
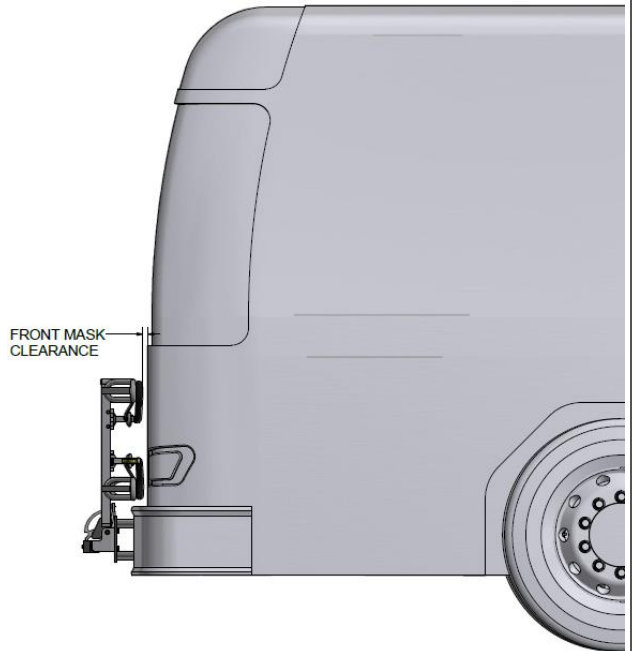

Mounting the DL2

Standard installation

The 2 Position Bike Rack mount to a Standard Pivot Plate. The Pivot Tab contacts the Pivot Plate in the Deployed position and the Frame contacts the Travel Stop Bar in the stowed position, shown below. 3/8 SS HHCS with Bronze Bushings are used to locate the Bike Rack onto the Pivot Plate. Torsion Springs are optional for 2 Position Bike Racks when Advertising Panels are installed onto the Bike Rack. Torque Specifications are shown in the next section.

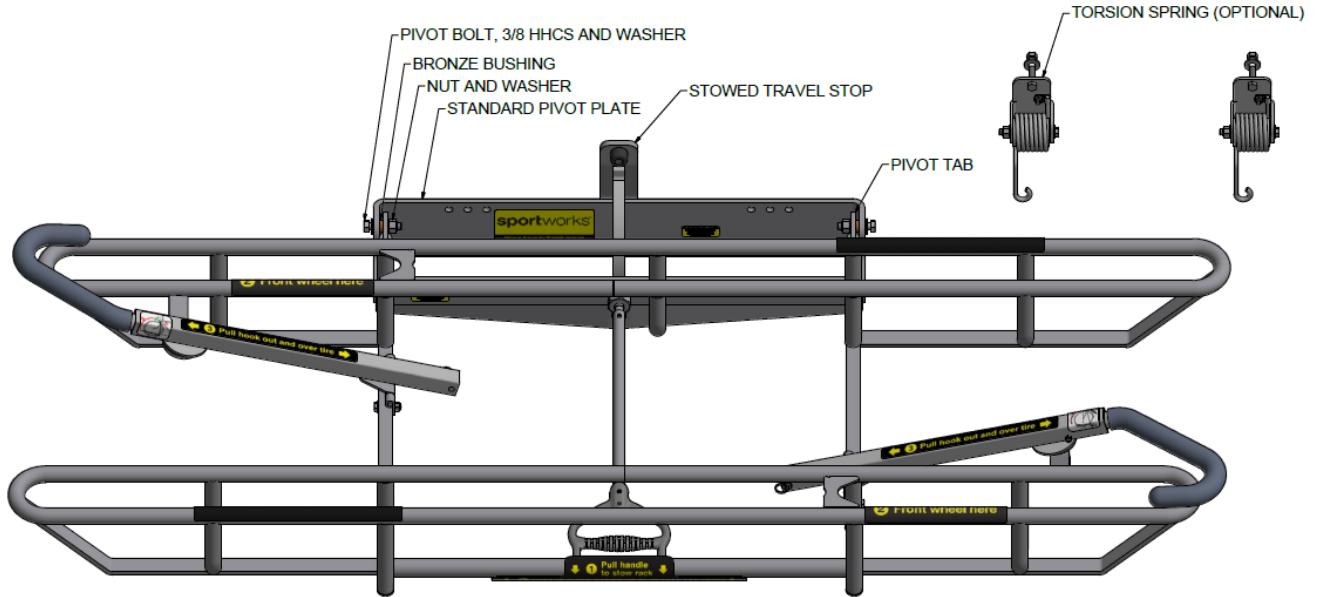

Optional Quick Release Installation

Quick release pivot hardware should be tightened by hand as tight as possible.



General Torque Specs

Most of our brackets are attached to the bus bumper using Grade 8 ½-13 HHCS. Our standard pivot plates are attached to the brackets using Grade 8 3/8-16 HHCS.

Recommended torque values:

- ½-13 Grade 8 – 80-90 FT-LB
- 3/8-16 Grade 8 – 30-40 FT-LB

If you are using quick-release hardware to attach the bike rack to the pivot plate or are using a Ten Second Bracket (TSB), please tighten the knobs by hand as tightly as possible and do not tighten with tools.

OPERATION OF THE BIKE RACK

The Sportworks Bike-Rack-for-Buses has been designed to make the lowest impact possible on transit operations. All loading and unloading of bikes can be done by the bike rider. Sportworks suggests that loading of children's bikes be done by an accompanying adult, though the rack can be easily loaded by young children.

Steps for Loading Bikes

1. Prepare your bike for loading. Remove water bottles, pumps, panniers, bags, and other loose items that could fall off while the transit vehicle is in motion.
2. Inform the transit operator that you will be loading your bike. You must load your bike from the curb or from in front of the transit vehicle. Do not step beyond the driver's side of the vehicle into passing traffic to load your bike.
3. If the rack is in the stowed (vertical) position, squeeze the latch handle to release the latch, then fold the bike rack down. You need only use one hand to unlatch and pull the bike rack down, so that your other hand is available to hold your bike. It is not necessary to lean your bike against the transit vehicle.
4. Lift your bike onto the bike rack, fitting your front wheel into a wheel slot labeled for a front wheel. The purpose of the directional placement is to make adjacent bikes easy to load and unload.
5. Raise the Support Arm Hook over the front tire. The primary purpose of the Support Arm is to keep the bike secure while the transit vehicle is in motion. Some bikes may sit in the wheel tray without use of the Support Arm, but the rack must not be used without the Support Arm

The Support Arm Hook must be between the highest point of the tire and the head tube. Incorrect Support Arm Hook placement may result in the bike falling from the rack, potentially damaging the transit vehicle or other vehicles. Place the Support Arm Hook over fenders as required to achieve the correct hook position. Some bike accessories such as front racks and baskets with vertical support stays may preclude correct hook placement. Bikes with accessories that conflict with correct support arm placement must not be loaded onto the rack.

6. Board the transit vehicle and enjoy the ride! Choose a seat near the front of the vehicle to keep an eye on your bike. **DON'T FORGET** you have a bike with you when you get off at your stop.

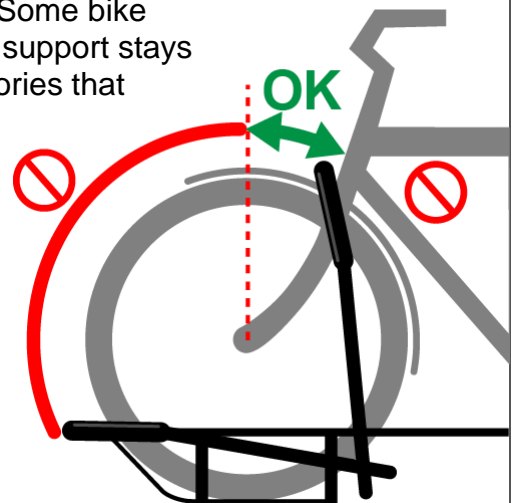

Steps for Unloading Bikes

1. Inform the transit operator driver that you will be unloading your bike as you approach your stop. Use the front door to exit the transit vehicle. Unload your bike from in front of the vehicle or from the curb, not from the street.
2. Raise the Support Arm Hook up and off the tire and return it to its stowed position.
3. Lift your bike out of the bike rack.
4. Fold up the Bike-Rack-for Buses if there are no bikes on the rack and no one else is waiting to load their bike. The bike rack will lock into place in the stowed position.
5. Step away from the transit vehicle with your bike onto the curb.

**PLEASE NOTE THAT
LOADING OR UNLOADING
A BIKE FROM THE STREET
SIDE OF THE TRANSIT
VEHICLE MAY CAUSE
INJURY OR DEATH..**

Sportworks label #3575 depicted below is available for use on the transit vehicle front fascia. The label measures 9.5 inches by 6.0 inches. It contains the same graphic in a larger format as the label affixed to each support arm of the rack.

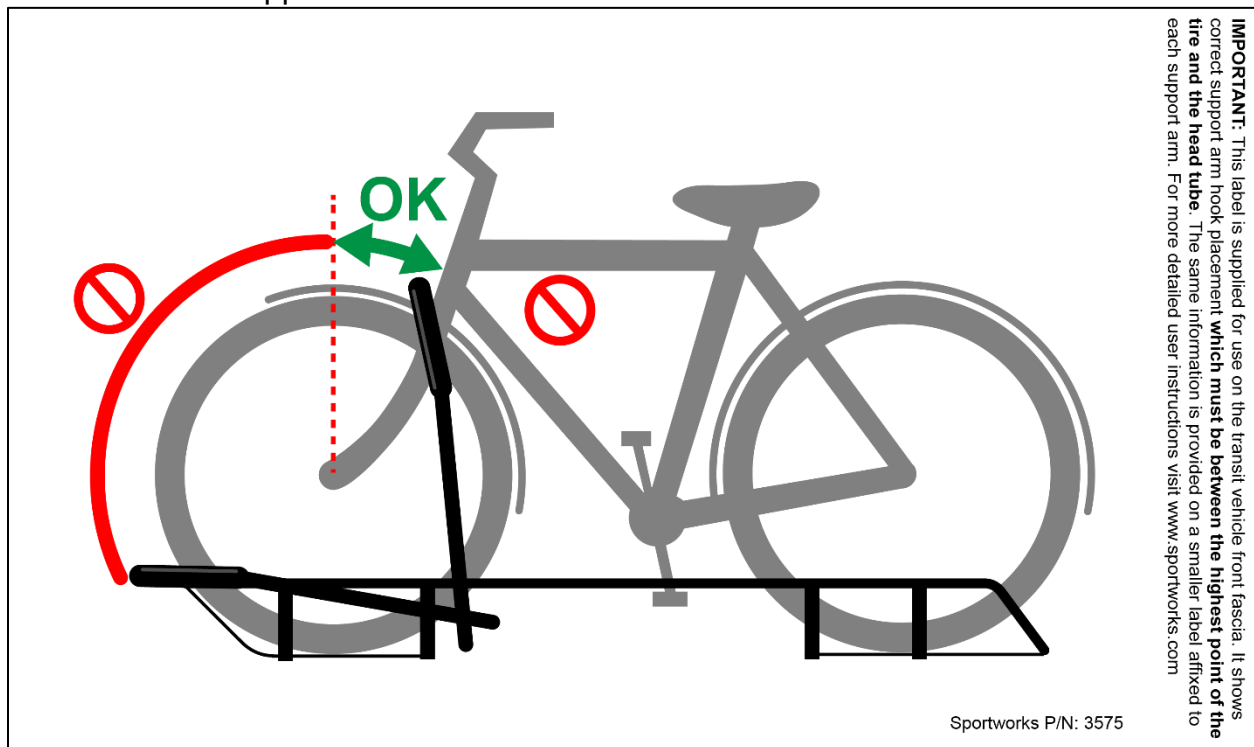

Compatible Bike Dimensions and Weight

To ensure safe bicycle fit within the DL2 rack family, each bicycle must comply with the following:

For DL2:

- Wheelbase (max): 44.0in
- Tire width (max): 2.3in
- Tire size (min-max): 20-29in (incl. 700c)
- Weight (max): 55lbs

For DL2 NP

- Wheelbase (max): 44.0in
- Tire width (max): 2.3in
- Tire size (min-max): 20-29in (incl. 700c)
- Weight (max): 55lbs

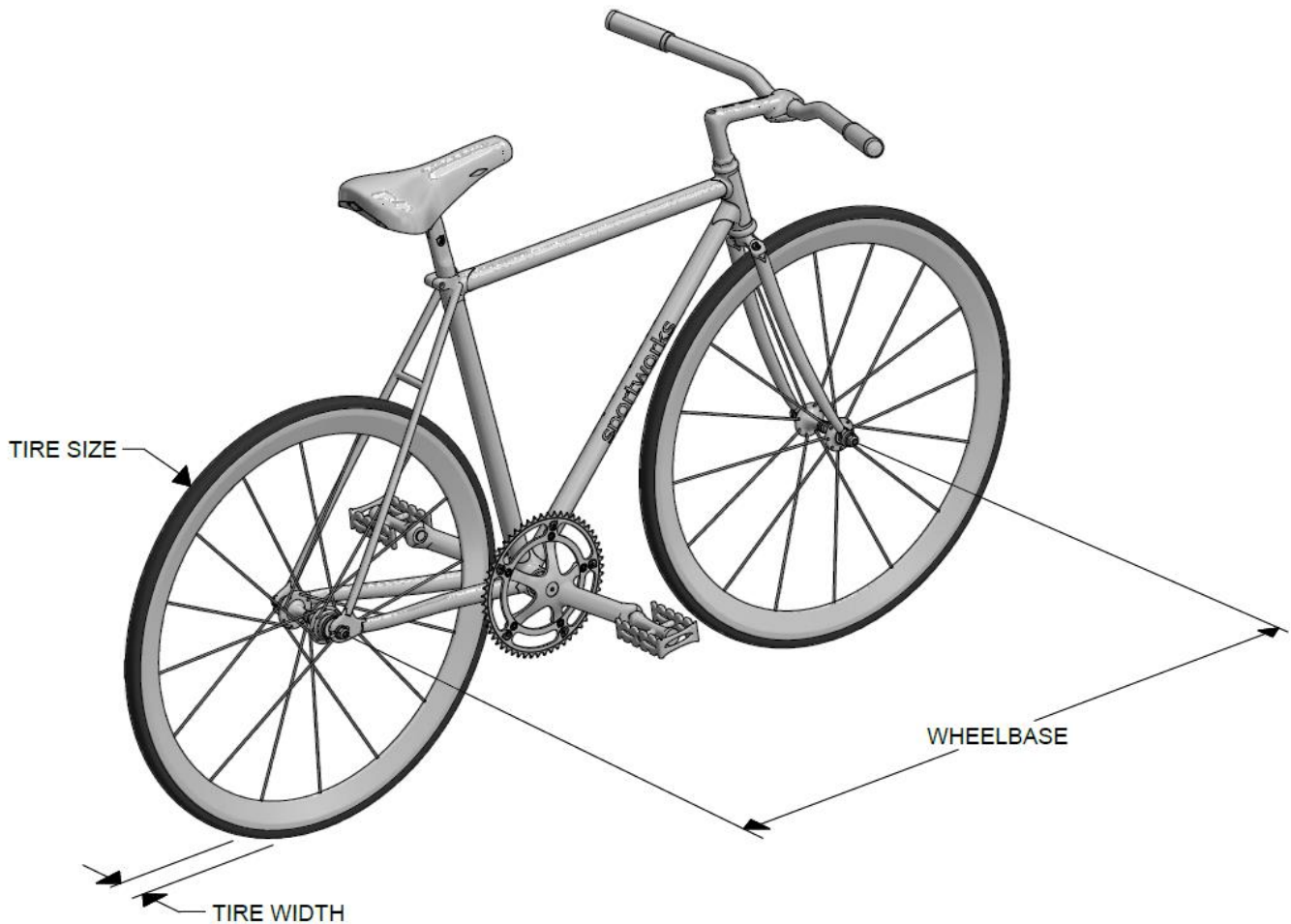

BUS WASHING

The Sportworks Bike-Rack-For-Buses has been designed to safely pass through bus wash facilities. Before taking a newly mounted bike rack through a wash facility, the operator should check to ensure that the wash facility is properly set up for washing the bus with a rack on it. Most wash systems use either a "top fixed" or "top and bottom fixed" spinning brush system. The Sportworks rack has been designed with round tubing and round edges so that the wash brushes address surfaces that will not catch or tear them.

Four types of conditions may cause excessive wear or harm to the bike rack or the wash system. None of these conditions should exist when running a bus with a bike rack through the wash facility:

1. The brushes are spinning at too slow of an RPM. This condition may allow the brushes to hook on protruding objects such as rear-view mirrors. If the axle of the brush assembly pushes deep against the rack or any part of the bus that has any sort of ledge, it may become caught there.

2. The bus is traveling too fast through the wash system. This may cause the same type of damage as stated in number one, above.

3. The brush density is too low. There is less than the recommended number of brushes on the brush arm assembly. This is usually found when well-worn brushes are used for too long of a period.

4. The brushes are being turned into the bus path. Make sure the brushes are spinning so that they tend to climb up and over any protrusions they could catch on. See Figure 1. The illustration shows the recommended rotation for the brush assemblies. If the brush assembly is fixed to the driver's side, the brush needs to rotate counterclockwise, as viewed from the top. If the brush assembly is mounted on the curb side, the brush assembly would need to rotate clockwise.

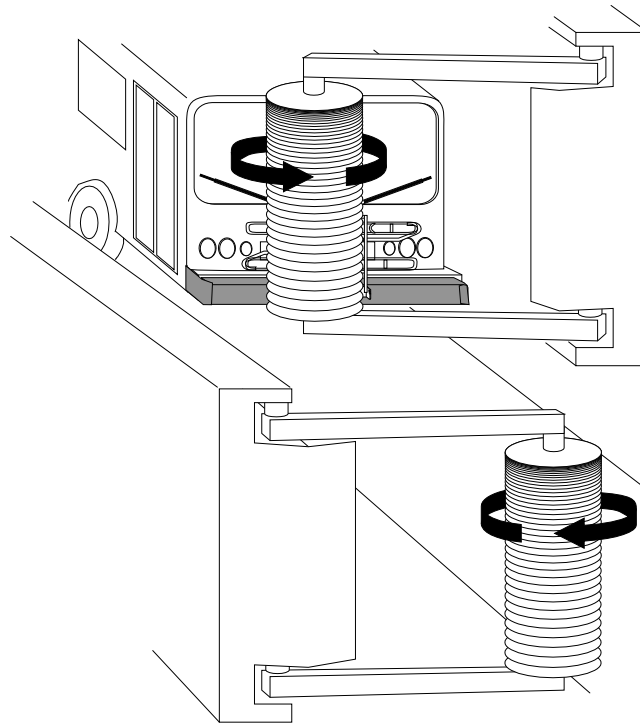

When operating the wash facility in the recommended way, one should find no deterioration above regular wear and tear to the bus, the bike rack and the wash system. If this is not so, take time to examine the rack setup on the bus and the setup of the wash facility. Please consult Sportworks at 425-483-7000 if you are experiencing any further problems.

VISUAL INSPECTION

Bottom View

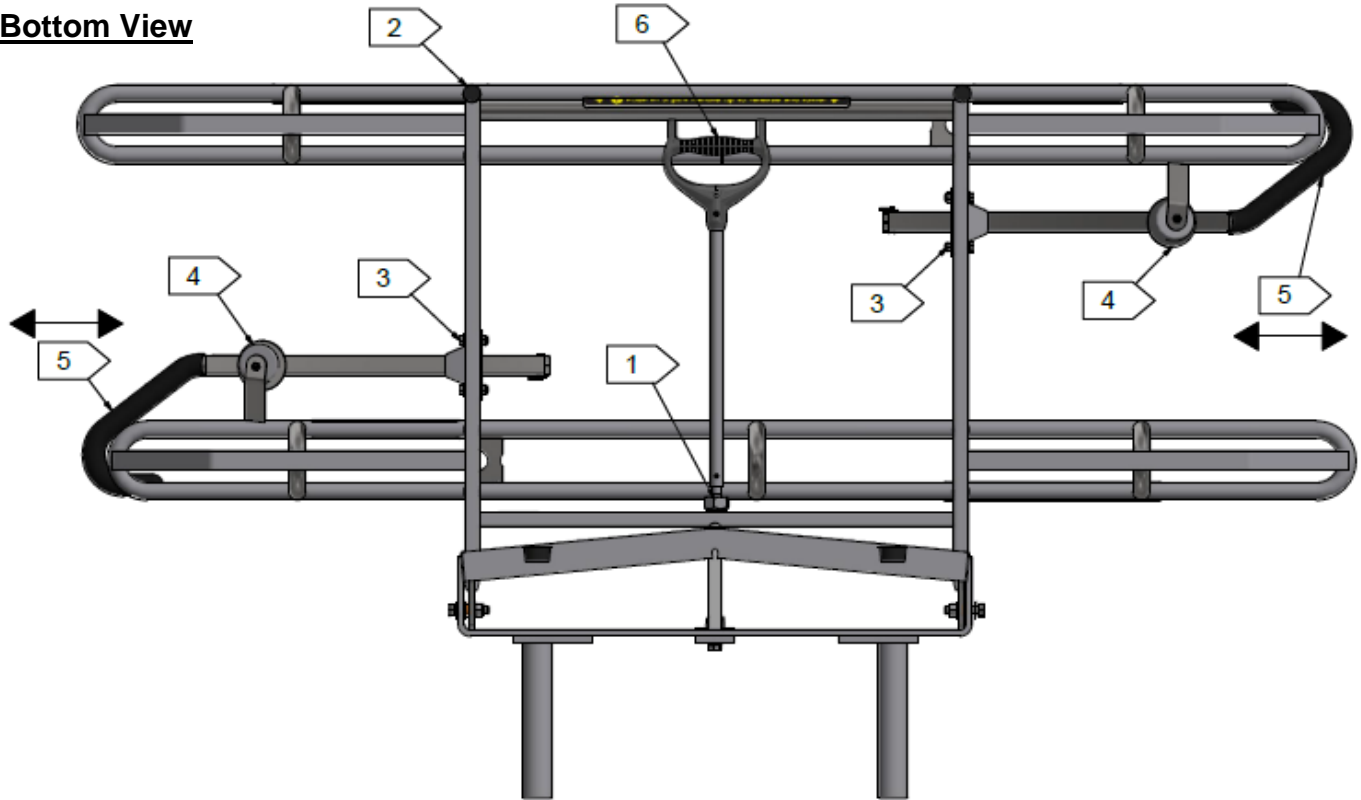

Side View

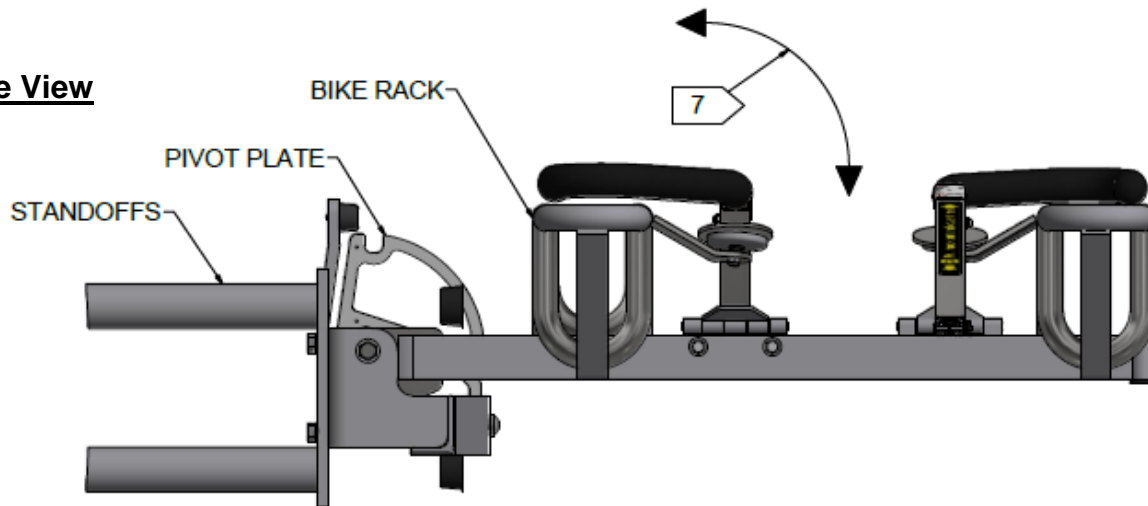

Visual Inspection Checklist

Sportworks recommends the following quick visual inspection to ensure an operable bike rack. Use this page as an inspection sheet for your transit operators.

Examine the 7 items below before operating your coach. If the bike rack does not function properly, service it before putting it into operation.

- 1) _____√ **HEX CAP IS TIGHT**
Tighten by hand (preferably by tool) if required.
- 2) _____√ **ENDPLUGS ARE PRESENT (2 PLACES)**
Replace plugs if missing or damaged.
- 3) _____√ **BOLTS ARE PRESENT—SECURE ARMS TO FRAME (4 PLACES)**
Replace missing bolts.
- 4) _____√ **MAGNETS ARE PRESENT (2 PLACES)**
Replace if missing. These magnets stow the hook arms.
- 5) _____√ **HOOK ARMS SLIDE IN/ OUT (2 PLACES)**
Hooks move smoothly in/out and self-stow on magnet.
DO NOT LUBRICATE.
- 6) _____√ **SUPPORT ARM SIDE PLAY NOT EXCESSIVE (2 PLACES)**
Verify that the Support Arm side to side play is less than 1.5" (measured at the hook with the arm retracted, but not resting on the magnet). Possible Causes: Broken or bent hinges, missing, broken or loose fasteners attaching the hinge to the frame, bent or broken support arm hook. Worn or missing bushings in the support arm housing.
- 7) _____√ **LATCH HANDLE WORKS**
The Release Latch easily unlatches, and the Latch Pin does not stick in the released position.
- 8) _____√ **BIKE RACK SWINGS FREELY AND LOCKS IN TWO POSITIONS**
Check Rack pivots and locks in both the deployed and stowed positions.

MAINTENANCE

The DL2 & DL2 NP Bike Rack and its accompanying brackets require very little service. **DO NOT LUBRICATE** any part of the bike rack. Sportworks has found lubricants may trap dirt/dust and inhibit the function of the rack. Regular suggested maintenance checks are included below.

Bottom View

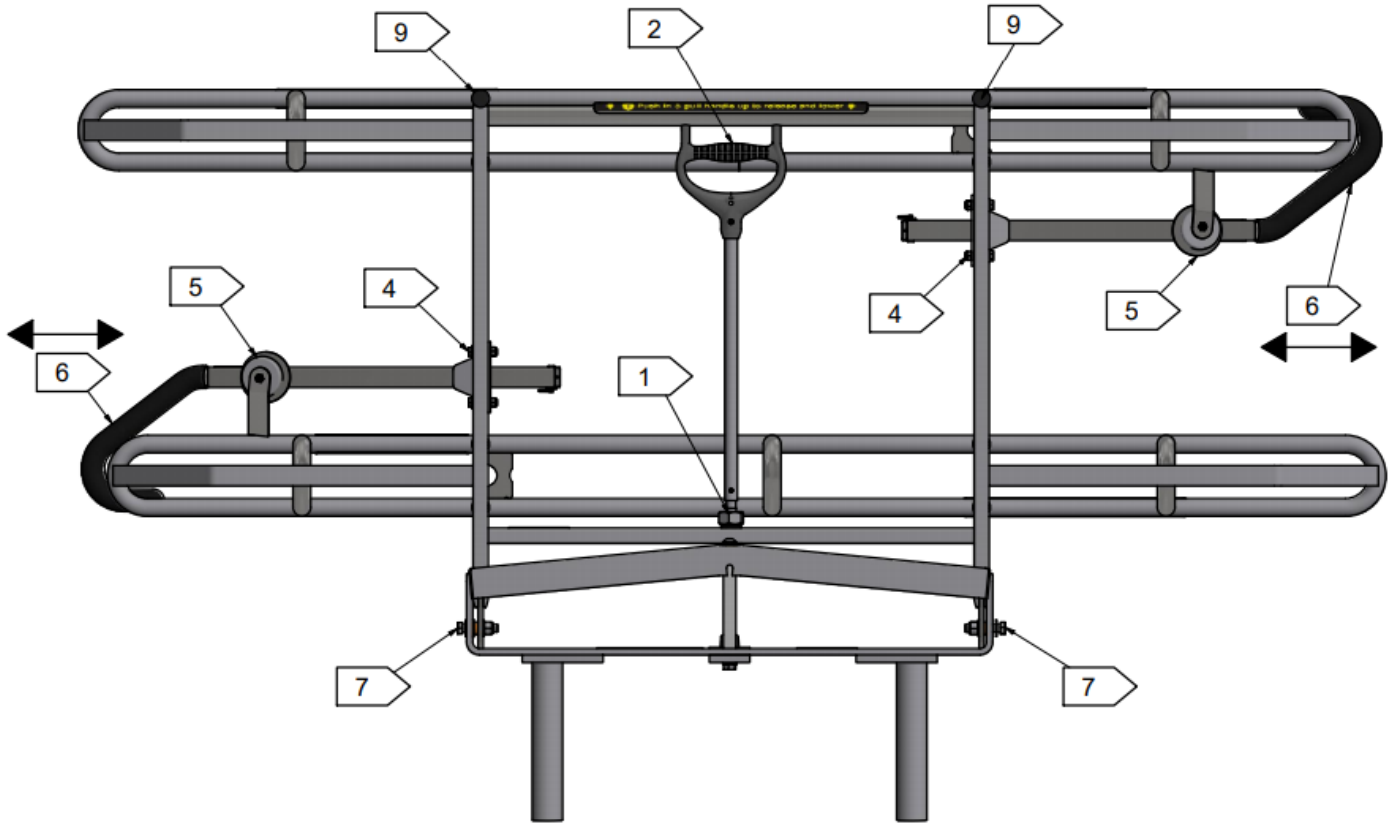

Side View

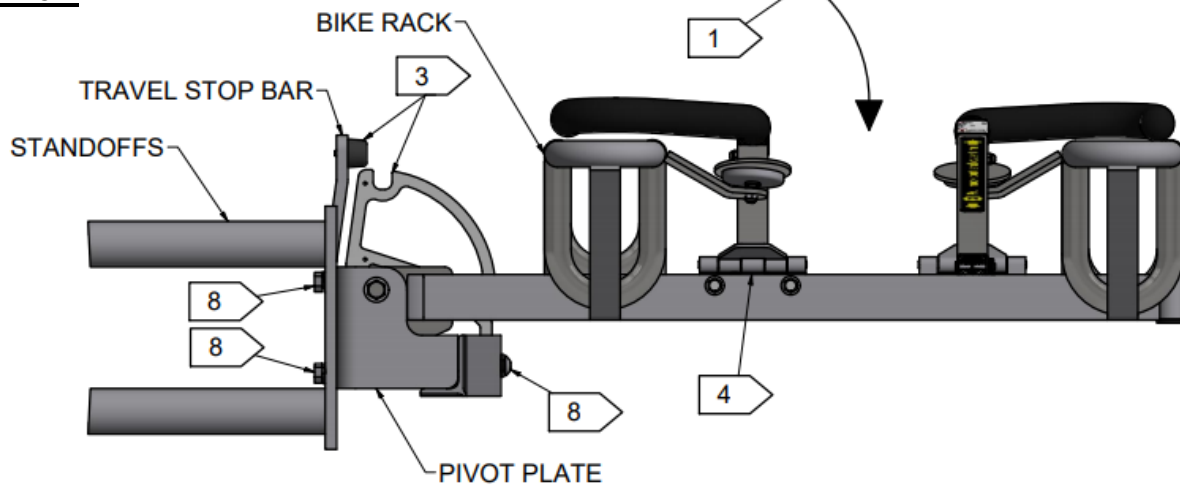

30 Day General Maintenance Inspection & Service

Check every 30 days to ensure that:

1. The rack swings freely and smoothly between the deployed and stowed positions.
2. The Release Latch easily unlatches, and the Latch Pin does not stick in the released position.
3. The release latch automatically locks the rack in place when moved to the deployed or stowed positions. Inspect both the travel stop bumper and the quadrant for wear. See Appendix A for more detailed troubleshooting.
 - a. Travel Stop: Bumper should not be torn, cracked or deformed. The bumper should apply light pressure to the bike rack in the stowed position, but it should not compress to the point where it is significantly deformed. If there is a gap between the bumper and the bike rack, then the bumper may be damaged, travel stop bar maybe bent, or other parts of the rack may be bent. Replace as needed.
 - b. Quadrant: Inspect wear in the notches that contact the bike rack latch pin. Replace if the wear exceeds these conditions: chord length of 0.35" (9mm) or a depth of 0.08" (2mm)
4. Each support arm hinge allows the support arm to raise and lower without undue constraint.
5. Inspect Support Arm Clevis Pin located at the lower end of the Support Arm. Inspect for wear in the area that the pin contacts the square Support Arm Housing and near the Split Ring. If wear is evident replace pin, washers and the split ring.
6. Each support arm magnet properly mates with and holds the support arm.
7. Each support arm hook pulls out smoothly, stops at the stop screw, easily slides back into the stowed position, and properly self-stows on the magnet when it is released.
8. Verify that the Support Arm side to side play is less than 1.5" (measured at the hook with the arm retracted, but not resting on the magnet). Possible Causes: Broken or bent hinges, missing, broken or loose fasteners attaching the hinge to the frame, bent or broken support arm hook. Worn or missing bushings in the support arm housing.
9. Both pivot bolt assemblies are tight. If using Quick Release hardware, ensure bolts are secured as tight as possible by hand. If you see excessive wear or cracks in the bronze oilite bushings you must replace them immediately. Some cutaway vehicles tend to cause the bushings to wear more quickly. You can replace the originals with our heavy-duty pivot bolt kit P/N 100839 for longer life.
10. All fasteners are tight on the bike rack and mounting bracket, including the hardware for the support arms, support strap, quadrant, pivot plate to bracket pieces, and bracket pieces to bumper or coach body.

11. There are two black plastic end plugs inserted into the main frame of the rack located near the ends of the lowering tube (the tube one grabs to engage the release latch). Replace if missing.
12. If installed, check Torsion Spring Wear Pad for excessive wear or loose attachment to frame and check that Torsion Spring Pivot Bolts are tight.
13. The instruction labels on the rack are intact. Replace if shredded, partially removed, non-readable, or not adhering properly. Clean the rack surface thoroughly (isopropyl alcohol) before replacing. Pay attention to the chain guard sticker.
14. If surface rust develops on stainless steel use naval jelly to remove.

APPENDIX A – Latch Interface Inspection

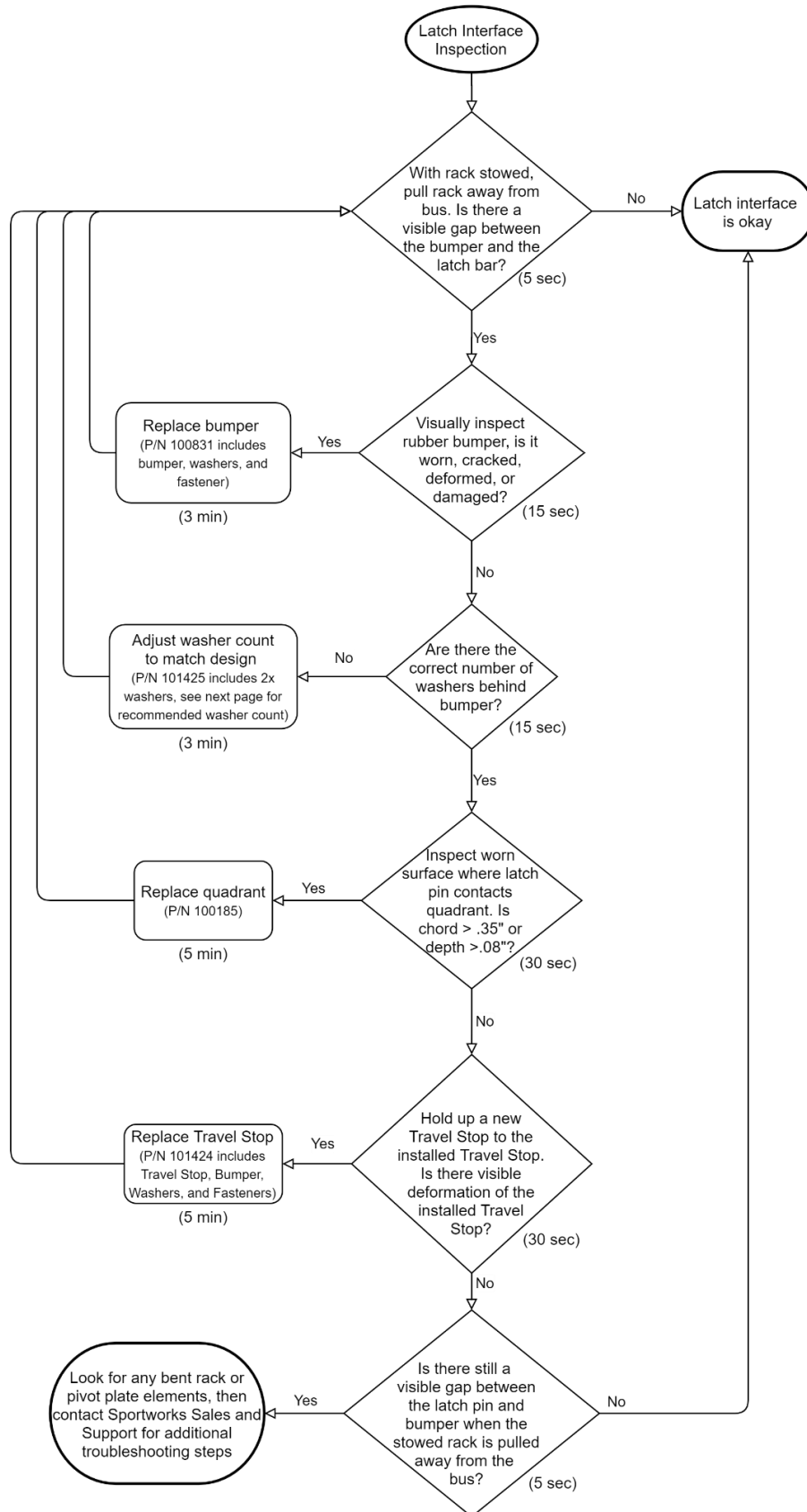

Travel Stop Washer Guide

The image below is a reference for how many washers should be present behind the travel stop bumper on different pivot plate designs. In general, if the back-plate of the pivot plate or TSB is 3/8" thick, there should be 2x washers. If the back-plate is 5/16" thick, there should not be any washers.

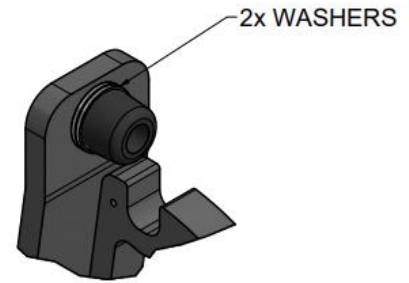
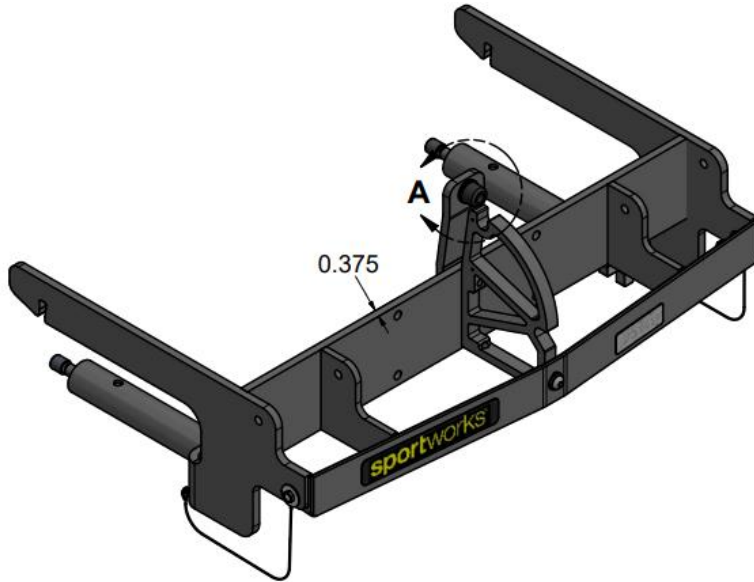

DETAIL "A"
TUBE HIDDEN FOR CLARITY

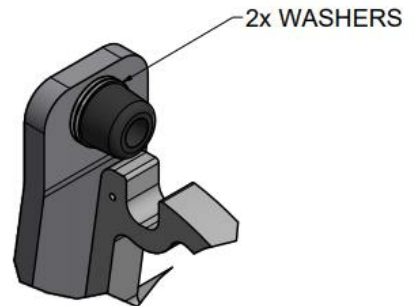
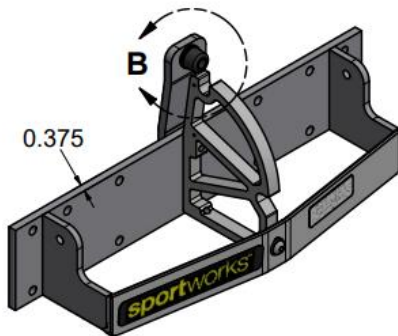

DETAIL "B"

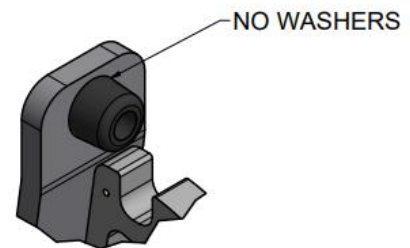
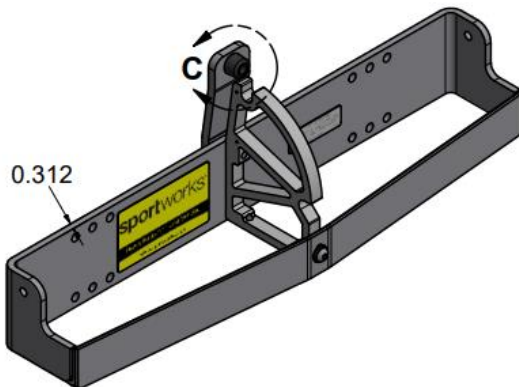

DETAIL "C"

DOCUMENT REVISION HISTORY

12/29/2020 – Initial release

2/2/2021 – Added additional “do not lubricate” statement