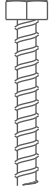

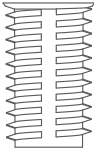
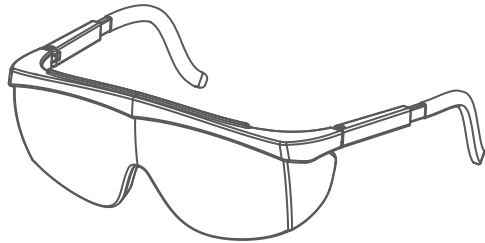
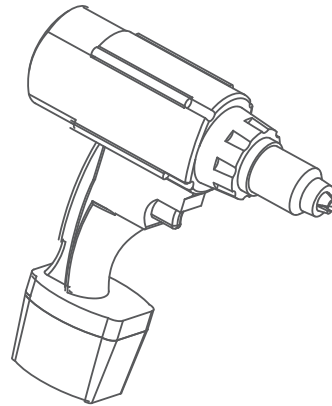

Image:	Anchor Type:	Page Number:
	Concrete Wedge Anchor	2
	Concrete Lag Screw	4
	Embed In Ground	6
	Asphalt Anchor	8
	Plywood Anchor	10
<p>Sportworks Northwest Inc. 15540 Wood Red Rd NE, Bldg A-200 Woodinville, WA 98072 www.sportworks.com Contact: Tel: 425-483-7000 Fax: 425-488-9001 salesandsupport@sportworks.com All dimensions and specifications nominal. Specifications are subject to change without notice. Copyright © 2020 Sportworks Northwest, Inc. All rights reserved.</p>		

Concrete Wedge Anchor - Required Tools



Safety Glasses



Hammer Drill

PILOT HOLES:



Carbide Tip
1/4" Concrete
Drill

3/8" ANCHORS:



Carbide Tip 3/8" Concrete Drill

1/2" ANCHORS:



Carbide Tip 1/2" Concrete Drill

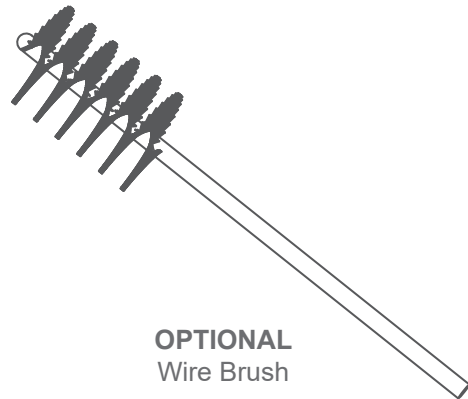

OPTIONAL
Wire Brush

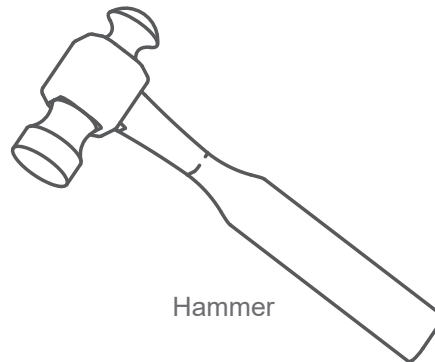

Hammer

3/8" ANCHORS:

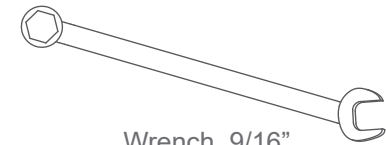

Wrench, 9/16"

1/2" ANCHORS:

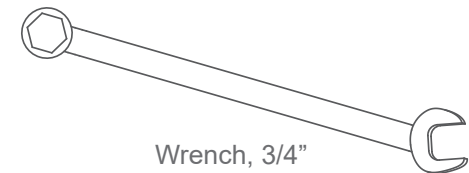

Wrench, 3/4"

Concrete Wedge Anchor - Installation Steps

1. Mark Holes

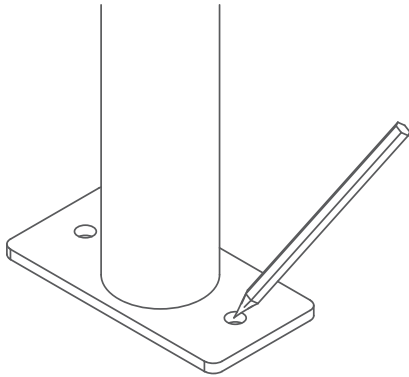

Set your bike rack in the location where you wish to install it. Use a pencil or center punch to mark hole locations on concrete using the bike rack feet as templates.

2. Drill Holes

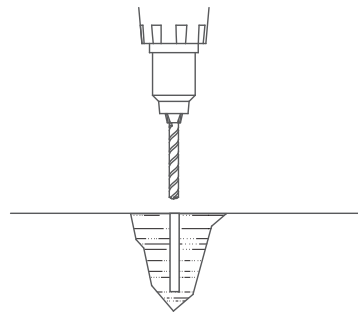

For best results, use carbide tipped drill bits. Start with a 1/4" drill bit and hammer drill to drill a pilot hole on each installation mark.

For 3/8" anchors use a 3/8" drill bit to drill out the pilot holes to a min. 3" depth, and for 1/2" anchors use a 1/2" drill bit to drill out the pilot holes to a min. 3.5" depth.

3. Clean Holes

Clean the dust out of the drilled holes with a shop vacuum.

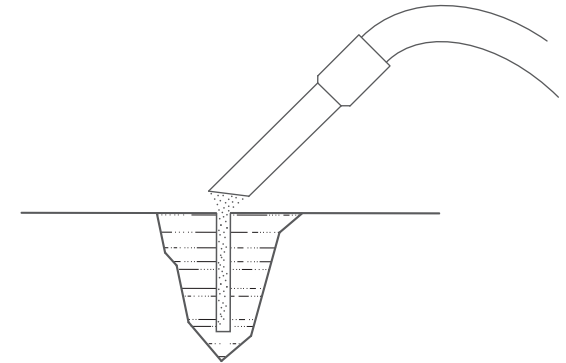

4. Set Rack and Level

Set rack so that holes in the mounting feet align with the holes drilled in Step 2. If the concrete surface is uneven use washers between the bike rack mounting plate and the concrete to level the rack.

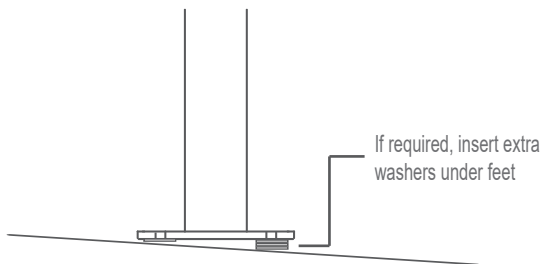

5. Hammer in Anchors

Insert anchor through bike rack mounting plate hole and drive the anchor into the hole with a suitable hammer. Ensure a min. of 5/8" of the anchor stud protrudes above the mounting plate or mounting rail for the nut.

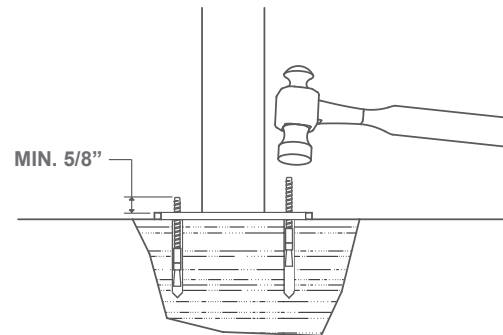

6. Tighten Nuts

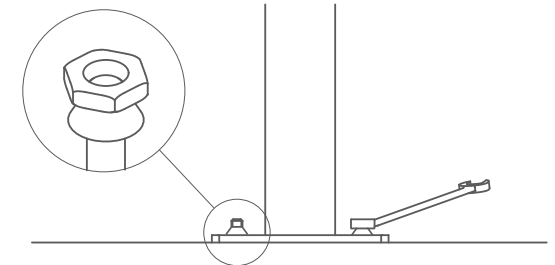

When all anchors are installed, thread nuts onto anchor studs. If using standard hex nuts, torque to 25 ft-lbs for 3/8" nuts, and 50 ft-lbs for 1/2" nuts. If breakaway nutes were provided, thread nuts onto studs ensuring the hex portion of the nut is facing up (detail shown). Tighten until hex portion breaks away and discard it.

Concrete Lag Screw - Required Tools

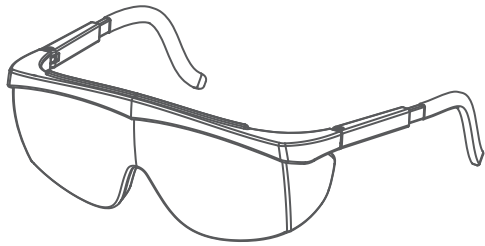

Safety Glasses

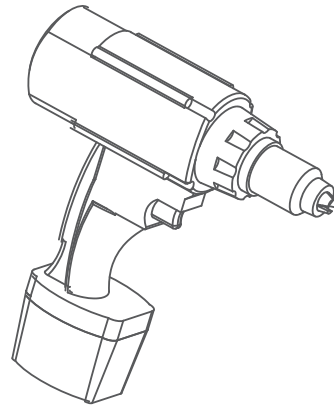

Hammer Drill

1/4" ANCHORS:



Carbide Tip 1/4" Concrete Drill

3/8" ANCHORS:



Carbide Tip 3/8" Concrete Drill

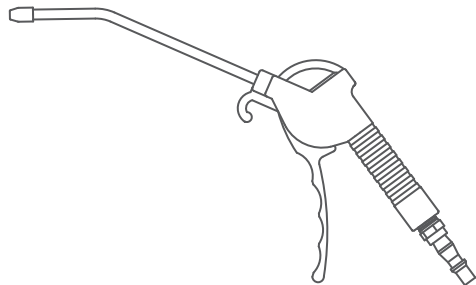

OPTIONAL
Blower and Compressed Air

1/4" ANCHORS:

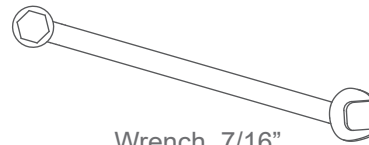

Wrench, 7/16"

3/8" ANCHORS:

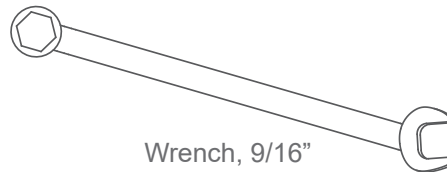

Wrench, 9/16"

Concrete Lag Screw - Installation Steps

1. Mark Holes

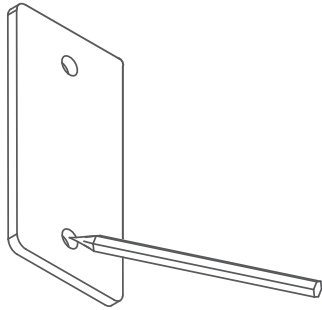

Set your bike rack in the location where you wish to install it. Use a pencil or center punch to mark hole locations on the wall using the bike rack mounting plate as a template.

2. Drill Holes

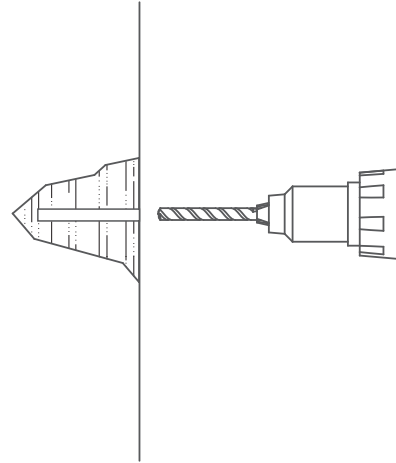

For drilling into concrete or brick, use a hammer drill and carbide tipped hammer drill bits that follow ANSI Standard B212.15.

When drilling through drywall or wooden studs, a hammer drill and carbide tipped drill bits are not required.

For 1/4" anchors, use a 1/4" hammer drill bit, and for 3/8" anchors use a 3/8" hammer drill bit. With the correctly sized drill bit and hammer drill, drill a hole on each of your installation marks.

The required minimum hole depth is 3" for the 1/4" anchors, and 3.5" for the 3/8" anchors. Or as specified by the anchor manufacturer.

3. Clean Holes

Clean the drilled hole with a wire brush, compressed air, or a vacuum.

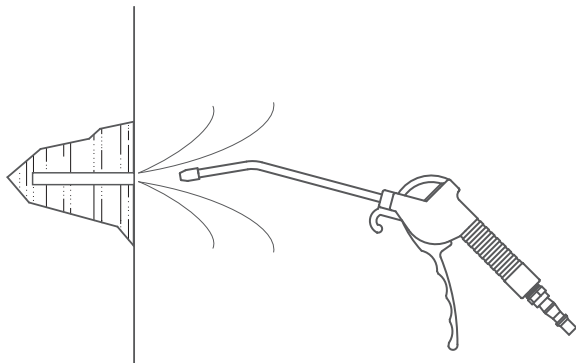

4. Screw Rack to Wall

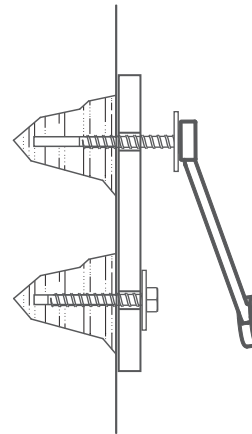

Set bike rack in place so that holes in the mounting plate align with the holes drilled in the wall.

Insert one lag screw through bike rack mounting plate hole and screw into place until the head of the screw contacts the mounting plate. For 1/4" anchors use a 7/16" wrench, and for 3/8" anchors use a 9/16" wrench.

Then insert another lag screw into the diagonally opposite hole in the mounting plate and screw into place until the head of the screw contacts the mounting plate.

Insert the remaining lag screws and screw into place until the heads of all the screws contact the mounting plate.

Once all screws have been inserted into place, tighten each one by one. For 1/4" anchors, torque to 18 ft-lbs, and for 3/8" anchors, torque to 40 ft-lbs.

Embed in Ground - Required Tools

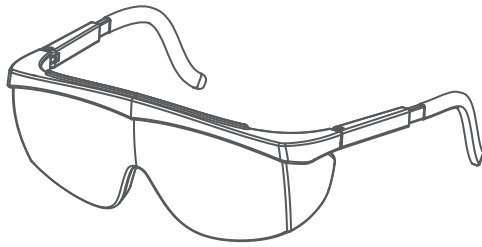

Safety Glasses

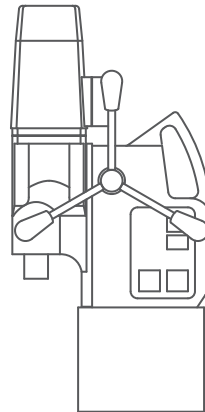

Electric Core Drill

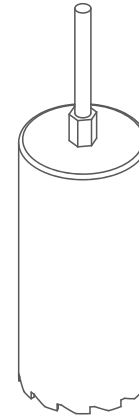

Core Drill (4" Diameter)

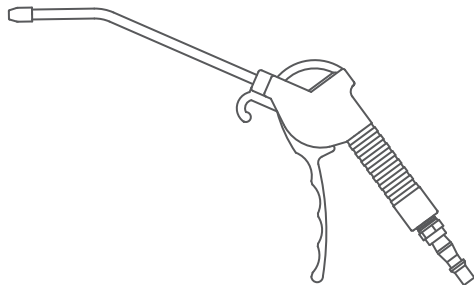

OPTIONAL
Blower and Compressed Air

Rebar
(3/8" Diameter)

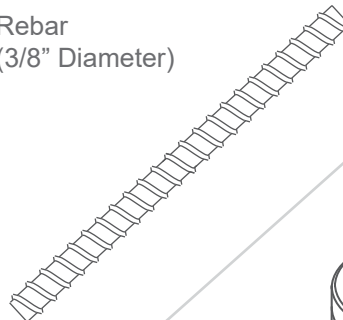

Epoxy
Grout

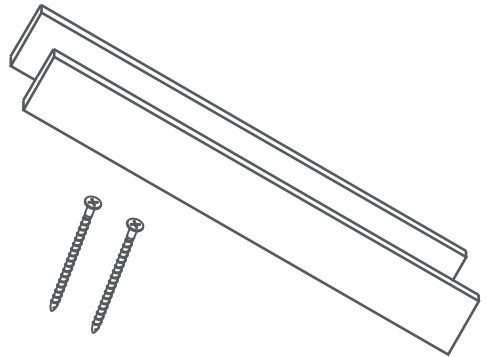

OPTIONAL
Wood Boards (1/2" x 4")
and Wood Screws

Embed In Ground - Installation Steps

1. Mark Holes

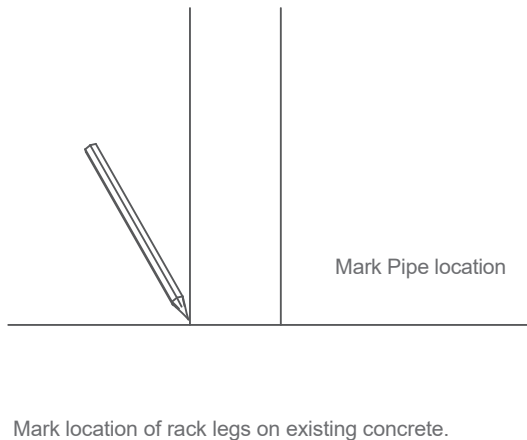

2. Core Holes

Core a minimum 4" diameter hole for each bike rack leg a minimum of 11" deep.

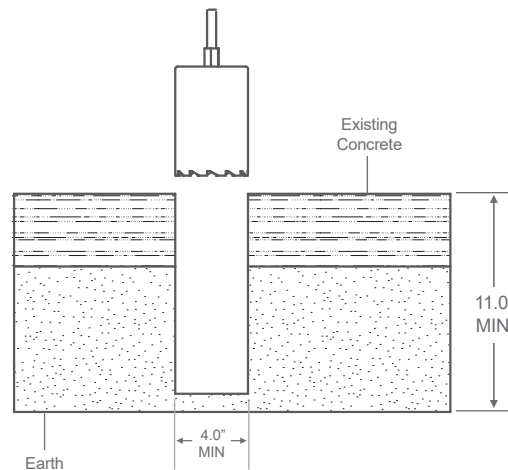

3. Clean holes

Clean the drilled hole with a wire brush, compressed air or a vacuum.

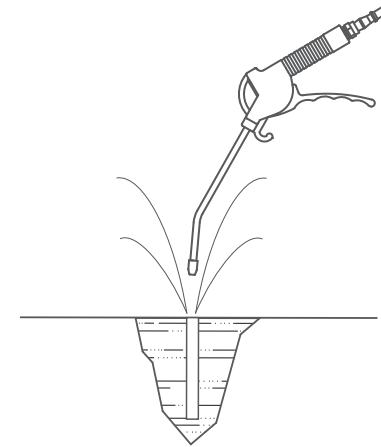

4. Position Rack

Insert a piece of rebar through the hole in each rack leg. Then insert rack legs into cored holes. Ensure the ends of each rack leg is positioned 10" below ground.

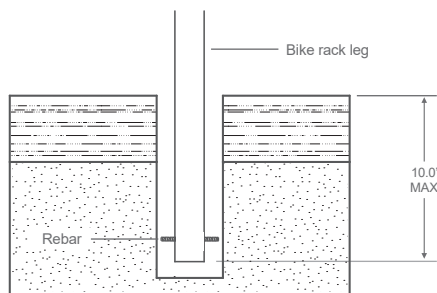

5. Pour Epoxy Grout

Embed bike rack into concrete using epoxy grout. Pour grout into each hole until filled level with the ground.

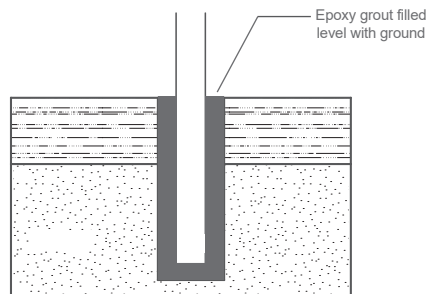

6. Hold Rack in Place

Wood boards can be used as shown below to hold the rack in place while the epoxy grout sets. Screw the ends of two boards together and splay the opposite ends open around the bike rack leg.

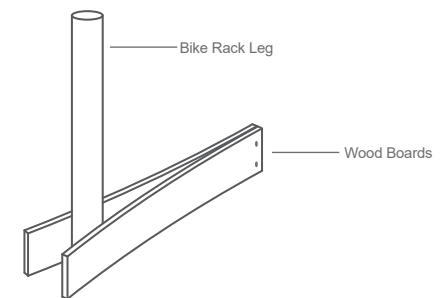

Asphalt Anchor - Required Tools

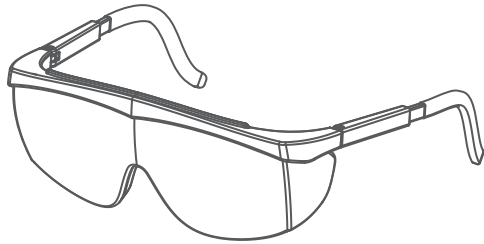

Safety Glasses

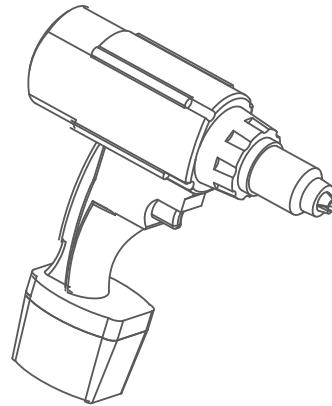

Hammer Drill

PILOT HOLES:



Carbide Tip
1/4" Concrete
Drill

SP12 ANCHORS:



Carbide Tip 7/8"
13" minimum length
Concrete Drill

SP18 ANCHORS:



Carbide Tip 1"
13" minimum length
Concrete Drill

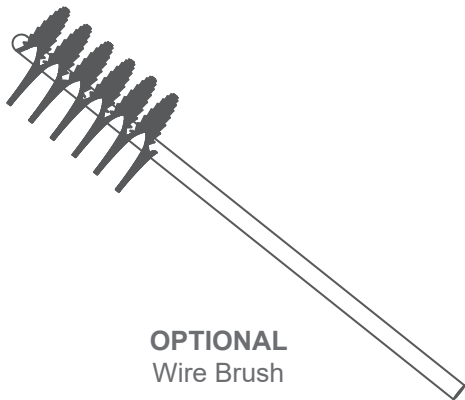

OPTIONAL
Wire Brush

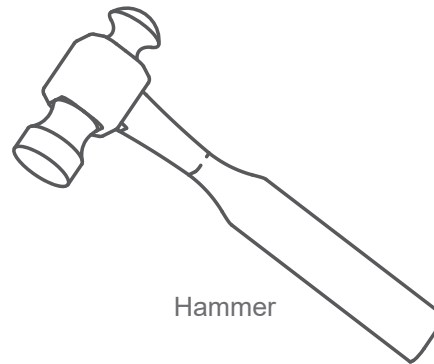

Hammer

SP12 ANCHORS:

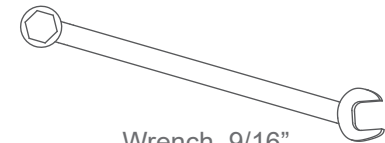

Wrench, 9/16"

SP18 ANCHORS:

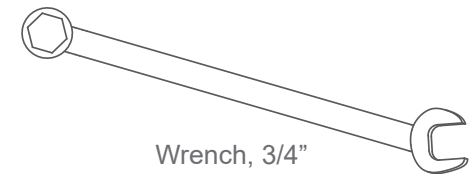

Wrench, 3/4"

Asphalt Anchor - Installation Steps

1. Mark Holes

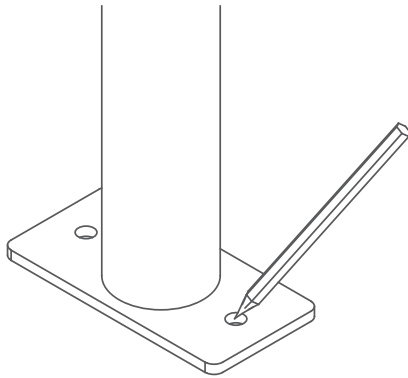

Set your bike rack in the location where you wish to install it. Use a white pen or center punch to mark hole locations on asphalt using the bike rack feet as templates.

2. Drill Holes

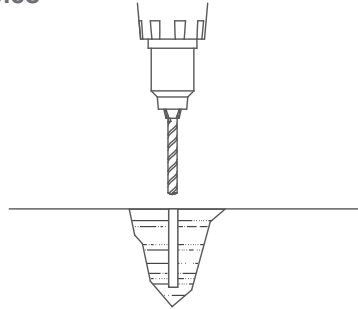

For best results, use carbide tipped drill bits. Start with a 1/4" drill bit and hammer drill to drill a pilot hole on each installation mark.

For SP12 anchors use a 7/8" drill to drill out the pilot holes to a min. 12" depth, and for SP18 anchors use a 1" drill bit to drill out the pilot holes to a min. 12" depth.

Drilling at least 1/4" deeper than the required depth will allow room for any debris to collect without interfering with the anchors.

3. Clean Holes

Clean the drilled hole with a wire brush and/or compressed air.

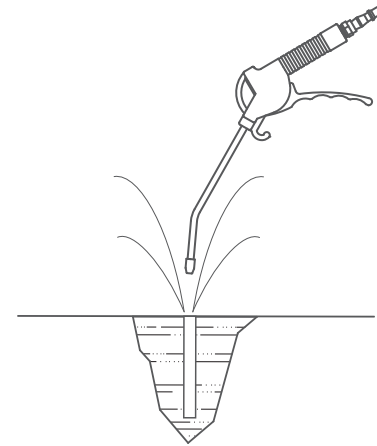

4. Mix Grout and Fill Holes

Add water to the grout in the bag and mix to a consistency of a syrup. Use the bag as a dispenser by cutting one corner off the bag. Fill each drilled hole with grout. Refill holes if necessary.

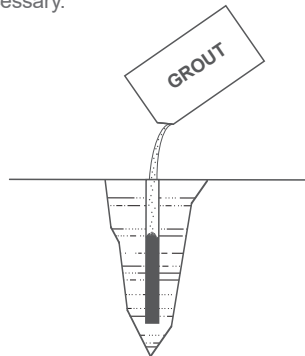

5. Install Anchors

Using a hammer, gently drive an anchor into each hole until the flange of the anchor is flush with ground. Make sure grout is visible all the way to the top. Add grout if required. Once the anchor is in place, wash the surface of the roadway to remove the excess grout. Let grout harden for about 20 mins.

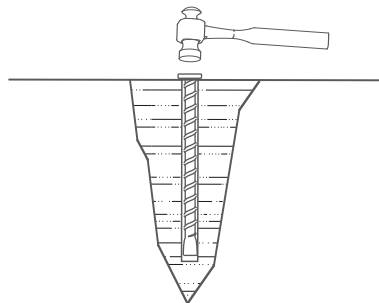

6. Tighten Nuts

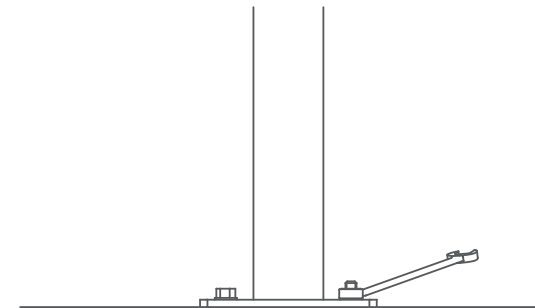

When all anchors are installed, place rack over anchors with holes in feet lined up. Screw in bolts provided and torque nuts to 25-30 ft-lbs for SP12 anchors, and 50-60 ft-lbs for SP18 anchors.

Plywood Anchors - Required Tools

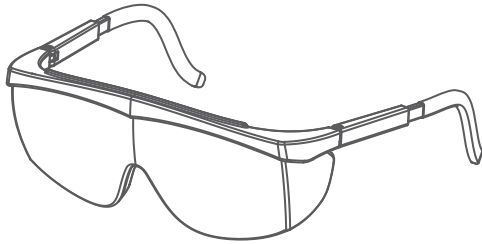

Safety Glasses

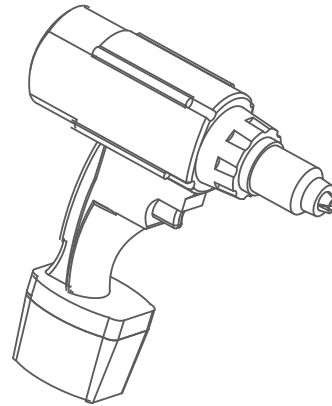

Drill

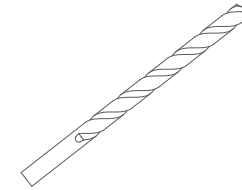

Pilot Holes: 1/4" Drill

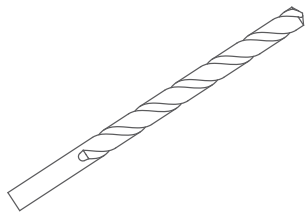

3/64" Drill bit

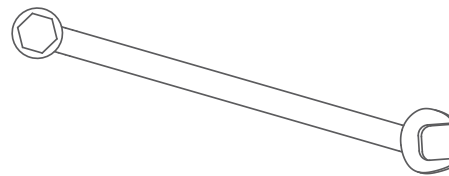

Wrench, 1/2"

Plywood Anchors - Installation Steps

1. Mark Holes

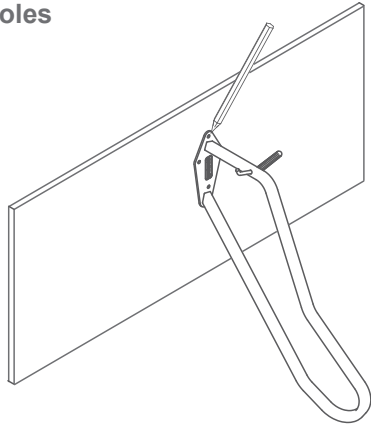

Ensure a 3/4" thick sheet of plywood has been securely anchored to studs or other structural members. Mark all fastener locations for the bike racks where you wish to install them on the plywood. If possible, use the rack/s as a template to mark hole locations.

2. Drill Holes

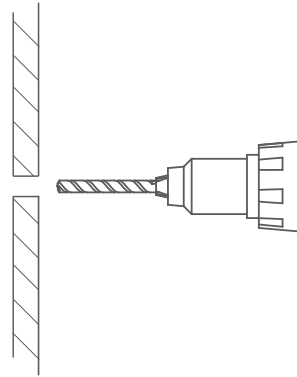

Using a 1/4" drill bit, drill a pilot hole on each of your installation marks all the way through the plywood. Then drill out all of these holes using a 3/8" drill bit.

3. Apply Glue

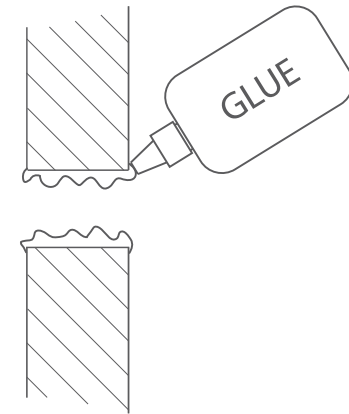

Apply some of the provided wood glue to each of the holes drilled in the plywood.

4. Install Inserts

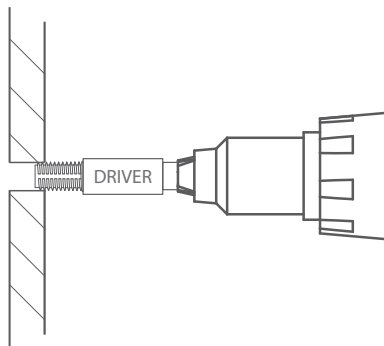

Install an E-Z Lock insert into each of the drill holes using the provided driver bit. Thread the inserts into the plywood until the flange flushes against the plywood.

5. Screw Rack to Inserts

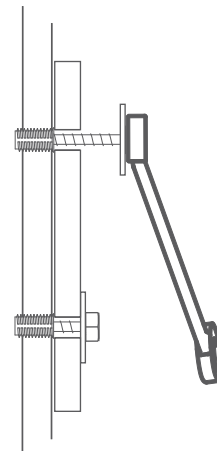

Set bike rack in place so that holes in the mounting plate align with the threaded holes in the inserts.

Install a hex head bolt (provided) through each hole and thread into the insert. Once all screws have been installed, torque each to 10 ft-lbs.