



MAINTENANCE GUIDE EASYLIFT PREMIUM

www.velopa.com



The Easylift Premium is extremely robust, thanks to the materials used to construct them. These materials also require a minimum of maintenance, and one annual inspection is generally enough to ensure that they are functioning correctly. VelopA has compiled this maintenance manual for that purpose.

In the following description, you can read more about how to carry out those maintenance checks. This description and the accompanying plans and diagrams will help you to identify any defects and/or wear and tear, and to remedy these. Any (dis)assembly of components must be carried out according to the assembly instructions.

For further technical details, please refer to the installation instructions (MI) for the Easylift Premium on www.velopa.com. *

Steps in the inspection process

1. Visual inspection: check the entire system and note any irregularities. Check the system for traces of vandalism.
2. Check all mountings and fastenings: see details 1-6 on diagram 1 (page 6). Check all visible nuts, bolts and screws to verify whether any are loose.
Action: Tighten any loose components in accordance with the assembly instructions. If any mountings or fastenings are loose, verify whether this applies to several systems or whether this is an isolated occurrence. If there appears to be a generalized problem, contact VelopA. *
3. Check the wheel clamps/locking loops/upper rail: verify whether any of the components in the lower rack and the upper rail have been bent/damaged. Action: Replace any damaged components if you notice damage that could affect the proper functioning of these elements. See diagram 2, details 7 and 8 (page 7).
4. Check handles: Verify whether the handles are providing a solid grip and do not feel loose. Loose handles are usually caused by:
 - Failure to properly attach the components of the handle to each other. Action: Replace (if necessary) or tighten the mounting and fastening elements.
 - Damage to the components of the handle which means that they are not attached securely to each other. Action: Replace the whole handle.

5. Check upper rail:

- a) Slide out the top rail without a bicycle, see diagram 3 point 1 (page 8). Check the outward movement and the guide rail. Stiffness in the upper rail is usually caused by:
 - A damaged upper rail, due to bending for example (e.g. vandalism). Action: Replace the upper rail.
 - Dirt that can accumulate in the path of the wheels. Action: Remove all dirt.

- b) Pull the upper rail out to its maximum extent (horizontally); the movement will be stopped by a stop element, see diagram 3 point 2 (page 8). Check that the stop element of the upper rail (front wheel end) is functioning correctly. This should create a robust buffer on the fixed section of the frame. The poor functioning of the stop element is usually caused by:
- Damage to the plastic elements. Action: Replace stop element.
 - Loose mountings and fastenings. Action: Tighten the mountings and fastenings.
- c) Lower the upper rail smoothly into the down position (without causing it to lock), see diagram 3 point 3 (page 8). The upper rail is now at an angle to the horizontal element. Check that the movement is smooth. If this movement is stiff, this is usually caused by:
- Faulty gas spring with too much pressure (see Table 1?1? for reference values). Action: Replace support arm.
 - Jamming of the primary hinge construction due to looseness between the hinge axis and the pivoting section. Action: Replace support arm.
- d) Slide the top rail down as far as it will go, see diagram 3 point 4 (page 8). The upper rail is now angled in relation to the horizontal element to the maximum extent. The upper rail should now lock itself in this position of its own accord. If the upper rail does not lock and does not move automatically back to the horizontal position (5) when it is released, this is usually caused by:
- Incorrectly aligned geometry in the gas-spring system. Action: Replace support arm.
 - An incorrect gas spring with too much pressure. Action: Replace support arm.
 - Insufficient space between chute and ground. Action: Adjust the position of the gas spring so that it remains in the resting position of its own accord.
- e) Move the upper rail upwards towards the horizontal position, see diagram 3 point 5 (page 5). An empty upper rail will move independently from lock position in a controlled manner. If the upper rail moves in an uncontrolled manner (too quickly), this is usually caused by:
- A faulty gas spring with too much pressure. Action: Replace support arm.
 - A faulty gas spring that does not provide enough damping. Action: Replace support arm.
 - Incorrectly aligned geometry in the gas-spring system. Action: Replace support arm.
- f) When the upper rail is horizontal, push it back into the resting position, see diagram 3 point 6 (page 8). The extent of this movement is limited by a stop element. Verify that stop element (back wheel end) is functioning correctly, see diagram 3 point 7 (page 8). This should form a sturdy buffer on the fixed section of the frame. A poorly functioning stop element is usually caused by:
- Damage to the plastic elements. Action: Replace stop element.
 - Loose mountings and fastenings. Action: Tighten the mountings and fastenings.



General recommendations

- 1.** Intermittent noise can be caused by elements rubbing/rolling against each other. If this occurs, lubrication must be applied. The fixed bearings should be lubricated with "Molykote BR2 plus". A datasheet is available on request from VelopA B.V. *
- 2.** A gas spring is a closed independent source of energy that functions smoothly and without requiring maintenance for many years due to its robust design. The reliability and service life of the gas spring can be ensured by:
 - Force combinations: gas springs should not be subject to exceptionally high (tensile and/or bending) forces.
 - Gas springs must be used regularly to prevent the desiccation of the internal barriers, causing gas pressure to be lost. Use between (preferably) once a day and (minimum) once a week is sufficient to ensure that this does not happen.
 - The amount of dirt or other contaminants on the piston rod. These contaminants cause damage to the internal seals, causing gas pressure to be lost.
- 3.** The gas spring has been tested to 20,000 movements in the presence of salt and water. No wear and tear was found after these tests. The warranty on the gas spring is 2 years.

Warnings:

- 1.** To avoid any chance of injury, the gas spring in the suspension system may not be opened or modified. This warning is also displayed on the gas spring itself. If the gas spring appears to be defective, contact VelopA B.V. *
- 2.** The frequency of cleaning depends on local conditions and natural wash-away due to rain. The frequency of cleaning will therefore vary from place to place. Cleaning can be carried out using a soft brush and plenty of water, possibly with a neutral synthetic detergent. All metals are subject to oxidization when dirt particles attach themselves to their surface, including stainless steel. This cannot be prevented. Dirt particles can be removed by hand (or by machine).
- 3.** Due to the open nature of the design, it is difficult for litter or fallen leaves to accumulate. Any litter can easily be removed with a high pressure cleaner or air blower, for example.

* North American customers should contact Sportworks Northwest, Inc. at 425-483-7000 or salesandsupport@sportworks.com.

Torque Table

	Torque (Nm)
M6	12
M8	40
M10	79
M12	136

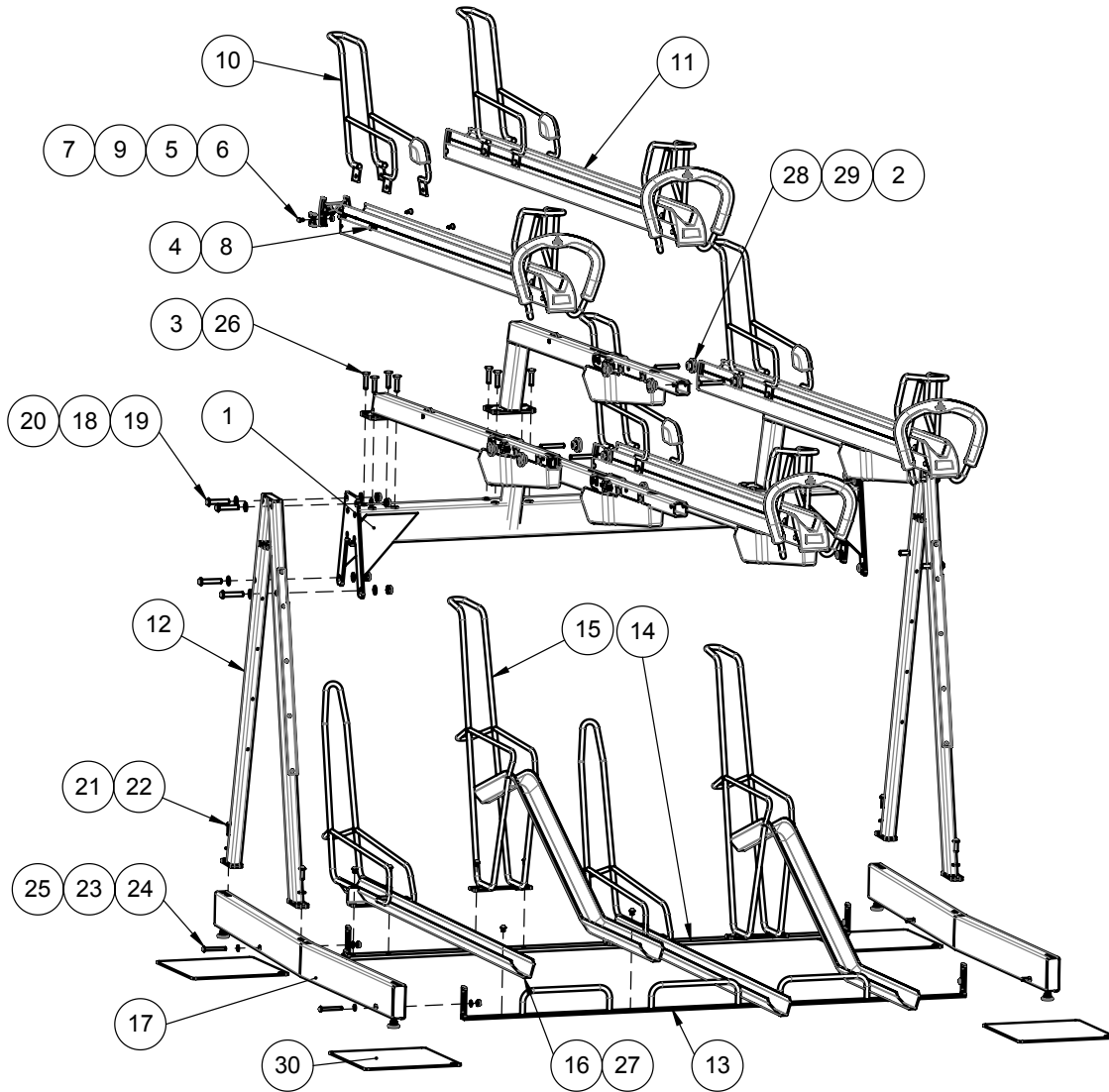

Pcs. no.	Qty.	Art.no.					Weight
1	1	30909112	Ligger 4 plaatsen enkelzijdig	Poutre 4 places unilatérale	Träger 4 Plätze einseitig	Girder C-C 400 - SS 4 pl. - Assembly	20.31
2	3	30909300	Console Premium - Hoog	Console Premium - Haute	Console Premium - Hoch	Console EL Premium - High - Assembly	10.82
3	2	30909310	Console Premium - Laag	Console Premium - Basse	Console Premium - Ebene	Console EL Premium - Low - Assembly	10.03
4	2	30909550	V-rail Premium - Laag	V-rail Premium - Bas	V-rail Premium - Bas	V-rail Premium - Low - Assembly	9.25
5	4	30910920	V-rail - Stop	V-rail - Bouchon	V-rail - Stopfen	V-rail - Stop	0.01
6	4		Bolkop met torx met pin (RVS)	Vis à tête bombée torx avec goupille (Inox)	Flachrundkopf mit torx mit stift (Edelstahl)	Torx button head with pin (SS)	
7	4	54320000	Borgmoer (RVS)	Ecrou bloquant (Inox)	Sicherungsmutter (Edelstahl)	Torque nut (SS)	
8	8	DIN 7981C - Ø6,3x16	Torx-schroef met pin (RVS)	Vis de Torx avec goupille (Inox)	Torx-Schraube mit Stift (Edelstahl)	Torx-screw with pin (SS)	0.01
9	1	30910925	V-rail Premium - Achterkap	V-rail Premium - Capot arrière	V-rail Premium - Heckhaube	Assembly - V-rail Premium - End cap	0.04
10	1	30909510	V-rail EL Premium - Voorwielklem	V-rail EL Premium - Pince de roue avant	V-rail EL Premium - Vorderradklemme	Assembly - V-rail EL Premium - Front wheel clamp Assembly	2.61
11	2	30909500	V-rail Premium - Hoog	V-rail Premium - Haute	V-rail Premium - Hoch	V-rail EL Premium - High - Assembly	9.65
12	2	30909201	Portaal - V-stand	Portail - V-stand	Portal - V-stand	Portal - V-stand - Assembly	11.96
13	1	30929810	B-rack - Ligger voorzijde	B-rack - Poutre avant	B-rack - Träger vorderseite	B-rack C-C 400 - Girder front - 4 pl. weldment	3.04
14	1	30909812	B-rack - Ligger midden enkelzijdig	B-rack - Poutre milieu unilatérale	B-rack - Träger mittlerer einseitig	B-rack C-C 400 - Girder middle SS - 4pl. Weldment	7.06
15	2	30909900	V-gutter - Hoog	V-gutter - Haute	V-gutter - Hoch	V-gutter - High - Weldment	8.23
16	2	30909910	V-gutter - Laag	V-gutter - Bas	V-gutter - Ebene	V-gutter - Low - Weldment	7.02
17	2	30909211	Portaal - Ligger enkelzijdig	Portail - Girder unilatérale	Portal - Bar einseitig	Portal - Girder - Assembly	10.29
18	16	54900420	DIN 125 - M12	Sluitring (RVS)	Rondelle (Inox)	Verschlußring (Edelstahl)	Washer (SS)
19	8	ISO 7380 - M12x60	Bolkop met torx (RVS)	Vis à tête bombée Torx (Inox)	Flachrundkopf mit Torx (Edelstahl)	Torx button head screw (SS)	
20	8	54900360	DIN 985 - M12	Borgmoer (RVS)	Ecrou bloquant (Inox)	Sicherungsmutter (Edelstahl)	Torque nut (SS)
21	4	54900410	DIN 125 - M10	Sluitring (RVS)	Rondelle (Inox)	Verschlußring (Edelstahl)	Washer (SS)
22	4	ISO 7380 - M10x30	Bolkop met torx (RVS)	Vis à tête bombée torx (Inox)	Flachrundkopf mit torx (Edelstahl)	Torx button head screw (SS)	
23	8	54900400	ISO 7089 - M8	Sluitring (RVS)	Rondelle (Inox)	Verschlußring (Edelstahl)	Washer (SS)
24	4	ISO 7380 - M8x65	Bolkop met torx met pin (RVS)	Vis à tête bombée torx avec goupille (Inox)	Flachrundkopf mit torx mit stift (Edelstahl)	Torx button head screws with pin (SS)	
25	4	54900340	DIN 985 - M8	Borgmoer (RVS)	Ecrou bloquant (Inox)	Sicherungsmutter (Edelstahl)	Torque nut (SS)
26	16	54990000	DIN 7991 - M10x40	Verz. schroef met torx met pin (RVS)	Vis à tête fraisee torx avec goupille (Inox)	Senkkopfschraube mit torx mit stift (Edelstahl)	Countersunk torx socket head screw with pin (SS)
27	12	ISO 7380 - M8x10	Bolkop met torx met pin (RVS)	Vis à tête bombée torx avec goupille (Inox)	Flachrundkopf mit torx mit stift (Edelstahl)	Torx button head screws with pin (SS)	
28	16	30910945	Console Premium - Loopwiel	Console Premium - Roue de guidage	Console Premium - Leitrad	Assembly - Console premium - Guide wheel	0.02
29	8	30910940	Console - As loopwiel	Console - Guide arbre de roue	Console - Leitrad Welle	Assembly - Console - Axis guide wheel	0.04
30	4	64001000	Druk verdeel plaat	Plaque de répartition de pression	Druckverteilerplatte	Pressure distribution plate	2.83

Torque Table

	Torque (Nm)
M6	12
M8	40
M10	79
M12	136

Drawing 1

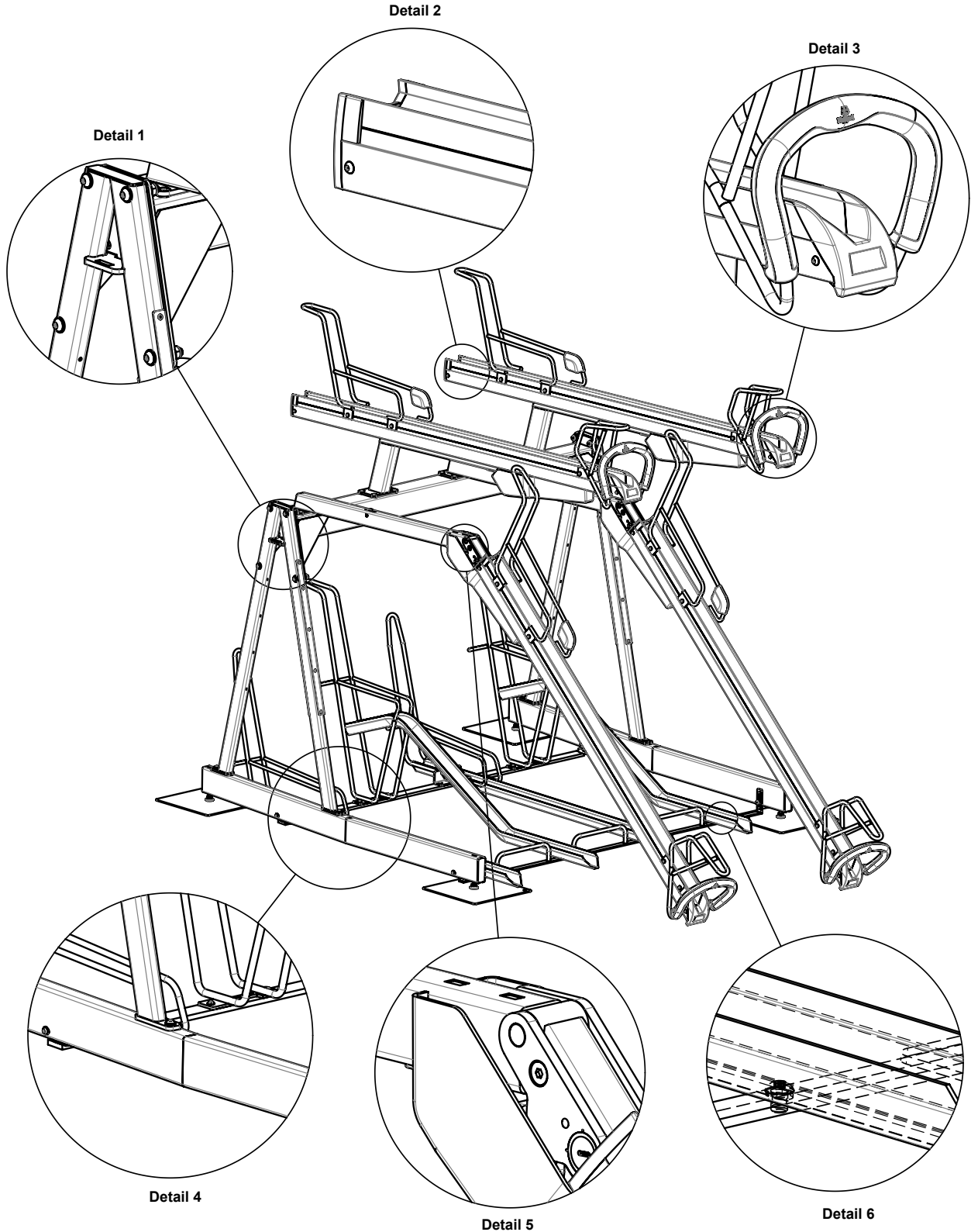

Torque Table

	Torque (Nm)
M6	12
M8	40
M10	79
M12	136

Drawing 2

Detail 7

Detail 8

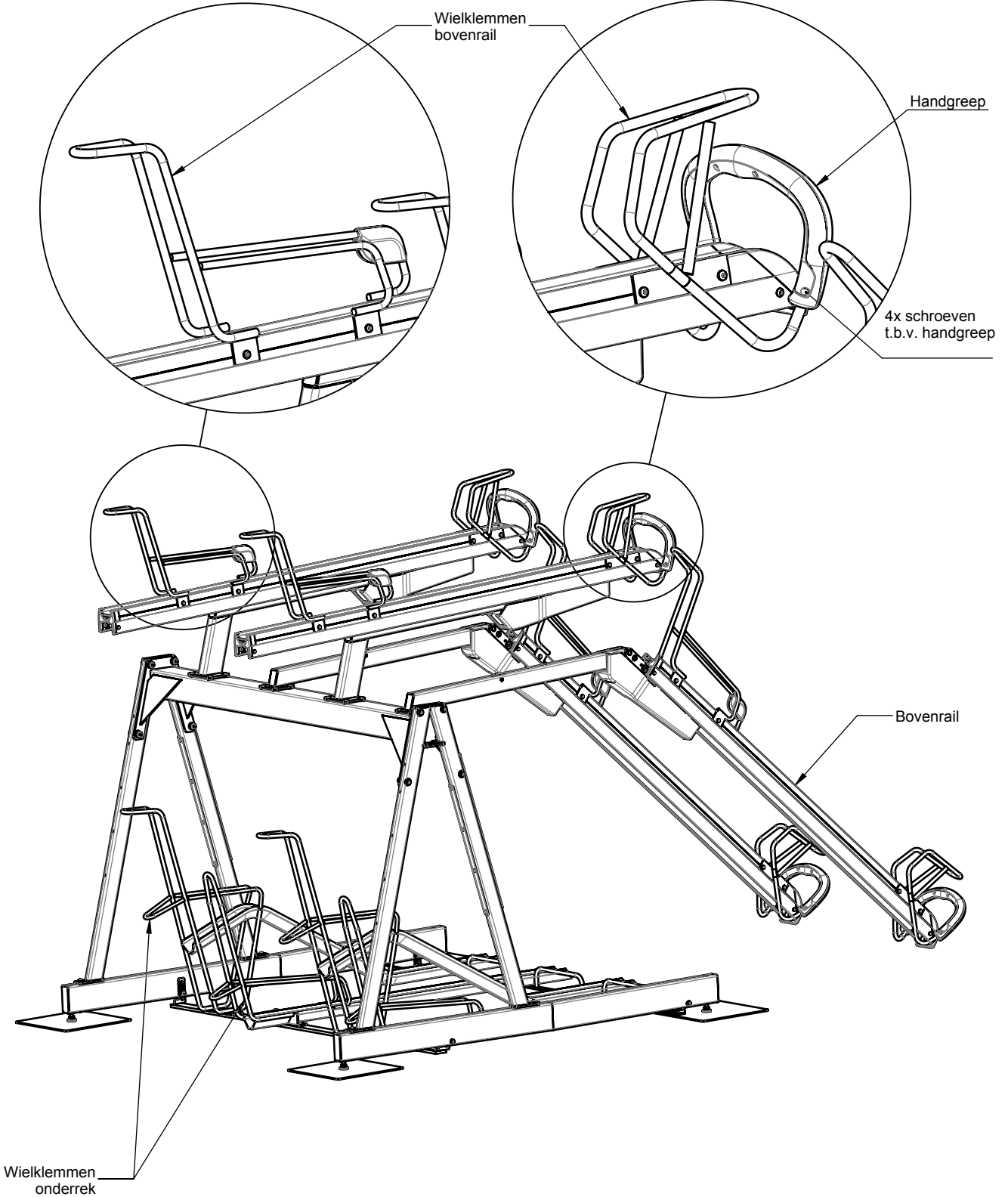

Torque Table

	Torque (Nm)
M6	12
M8	40
M10	79
M12	136

Drawing 3

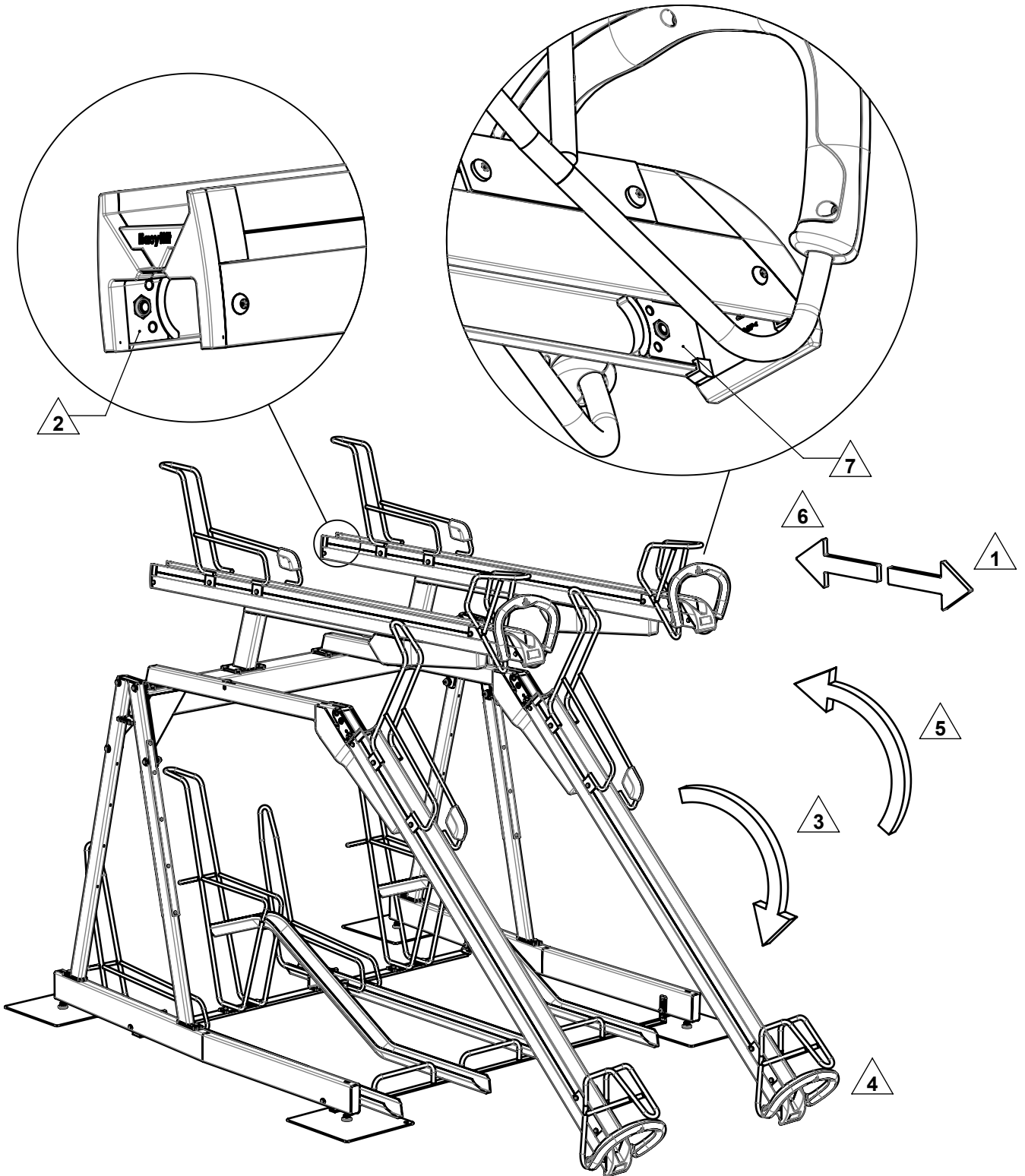

Torque Table

	Torque (Nm)
M6	12
M8	40
M10	79
M12	136

Laatste controle / Vérification finale / Endkontrolle / Final check

1. Hoek van 2° is benodigd voor afwatering en dient tevens als uitrolbeveiliging
1. Winkel von 2° wird für die Entwässerung benötigt und dient auch als Rückrollsicherung
1. Un angle de 2° est indispensable pour les écoulements d'eau et le maintien du vélo
1. Angle of 2° is needed for drainage and also serves as roll out security

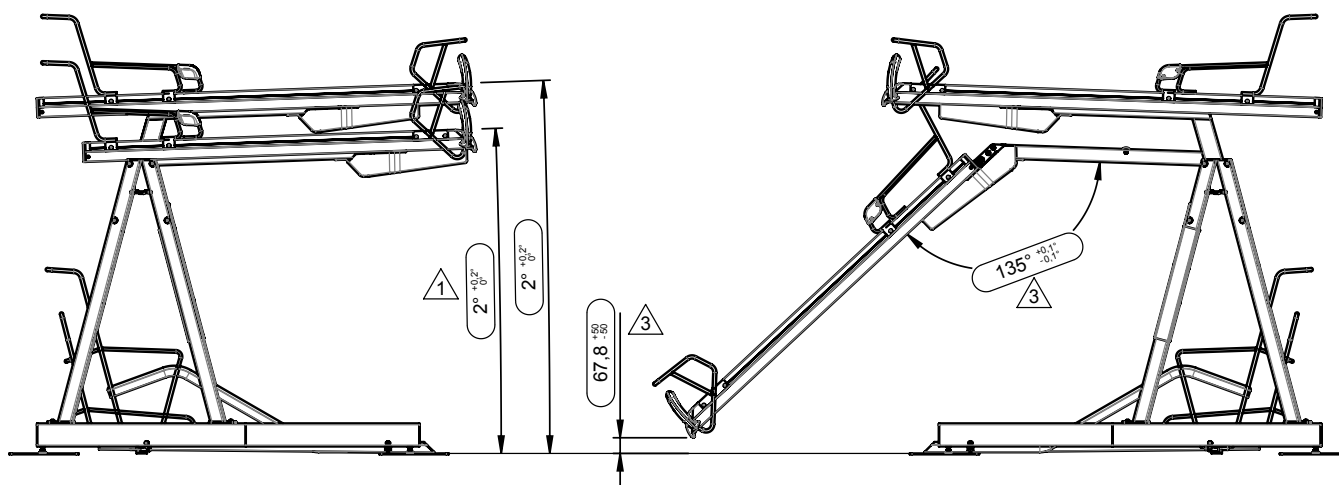

2. V-rail moet in en uit geschoven worden op de geleiding te controleren
 2. V-rail doivent être tirés dans et hors de vérifier la direction
 2. V-rail (Schiene) muss eingeschoben und ausgezogen werden, um die Geläufigkeit zu überprüfen
 2. V-rail must be pulled in and out to check the guidance
3. Controleer hoek en hoogte voor correcte werking van het scharnier
 3. Vérifier l'angle et la hauteur pour le bon fonctionnement de la charnière
 3. Überprüfen Sie den Winkel und die Höhe für einen ordnungsgemässen Betrieb des Scharniers
 3. Check angle and height for proper operation of the hinge

Table showing reference values for gas spring

	Height 0 cm from ground level	Height 135 cm from ground level	Height 170 cm from ground level
Bearing the load of a bicycle, max. 20 kg.			
Without bicycle	2 kg	0 kg	0 kg
With bicycle	17 kg	15 kg	10 kg
Damping factor			
With bicycle downwards	1.1 sec	0.4 sec	0 sec



Inspection form Easylift Premium

Name project		Customer		Position	
Address location		Supervisor		Row	
Inspection date				Bike space	

Element	Aspect	Findings (please circle the appropriate answer)	
General	1) Visual inspection 2) Check fasteners 3) Check wheel clamps & securing loop 4) Checking the handle 4) Check for damage 5) Check for vandalism	OK OK OK OK No damage Vandalised* ¹	not OK not OK not OK not OK Damage* ¹ No vandalism <small>*¹ If so, take pictures and report</small>
Remarks		General flaws	
		Maintenance advice	
		Fix / Fasten	
		Replace	

Element	Aspect	Findings (please circle the appropriate answer)	
Upper level	7) Check operation a. Check rolling movement b. Check in lower position 8) Check wheel clamps	Works well OK OK OK	Does not work well Does not work well Does not work well Not OK
Remarks		General flaws	
		Maintenance advice	
		Fix / Fasten	
		Replace	



CLEANING & MAINTENANCE SERVICE

Easylift Premium and CapaCITY are the most user-friendly and reliable dual-level bicycle parking systems on the market. Since 2011, we have realized more than 90,000 bicycle parking spaces with our dual-level bicycle parking systems, which are in daily use at various locations in the Netherlands and abroad, to the full satisfaction of those that use them. When the Easylift Premium and CapaCITY were under development, the aim was to ensure the lowest possible maintenance requirements to ensure operational reliability. Nevertheless, routine inspections, (preventive) maintenance and regular cleaning of the system are recommended.

Maintenance contract

Your peace of mind is important to VelopA. We can offer you the possibility of a maintenance contract for the Easylift Premium.

For sales and support in North America:
Sportworks Northwest, Inc.
425-483-7000
salesandsupport@sportworks.com
www.sportworks.com